

An Artificial Atom

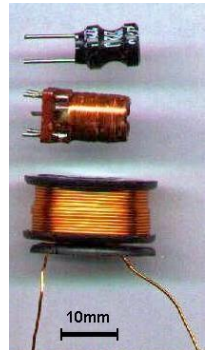

<https://pixabay.com/de/illustrations/atom-symbol-zeichen-abstrakt-68866/>

https://upload.wikimedia.org/wikipedia/commons/2/2c/Diverse_Spulen.JPG
[https://de.wikipedia.org/wiki/Kondensator_\(Elektrotechnik\)](https://de.wikipedia.org/wiki/Kondensator_(Elektrotechnik))

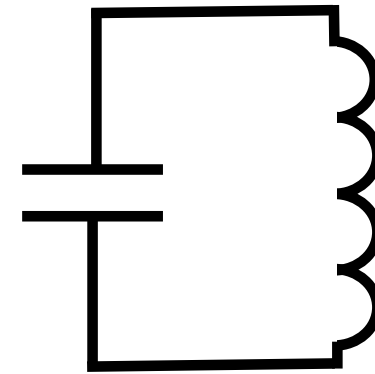
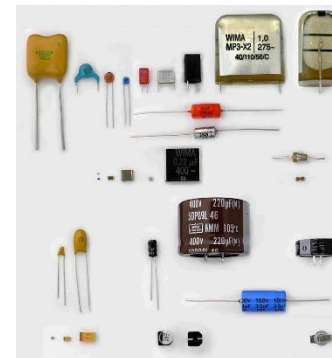
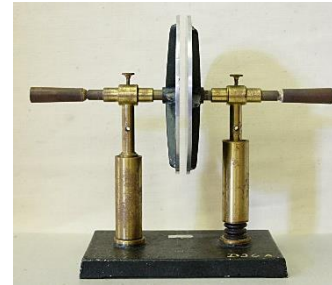
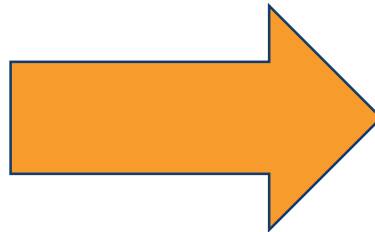
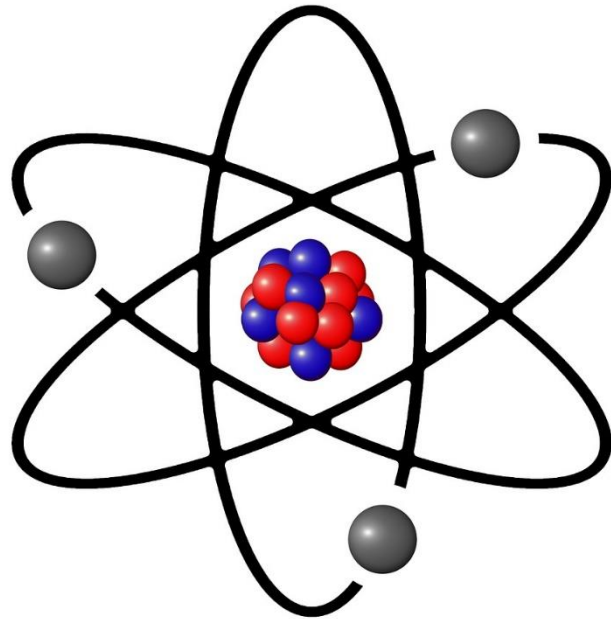

ÖAW
ÖSTERREICHISCHE
AKADEMIE DER
WISSENSCHAFTEN

FWF
Der Wissenschaftsfonds.

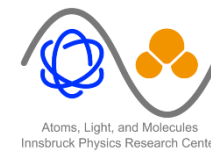

universität
innsbruck

Circuit QED with Superconducting Qubits

Maximilian Zanner
MIP Seminar 2019/11/29

- Introduction
 - What is a Superconductor?
 - Electrical Circuits
- Circuit QED
 - Josephson Junctions
 - Quantum Information Processing
- Waveguide QED
 - Mirror-like Atom
 - Qubits in a Waveguide

What is a Superconductor?



Superconductivity & Application

- No Resistance below T_c
- No Information Loss

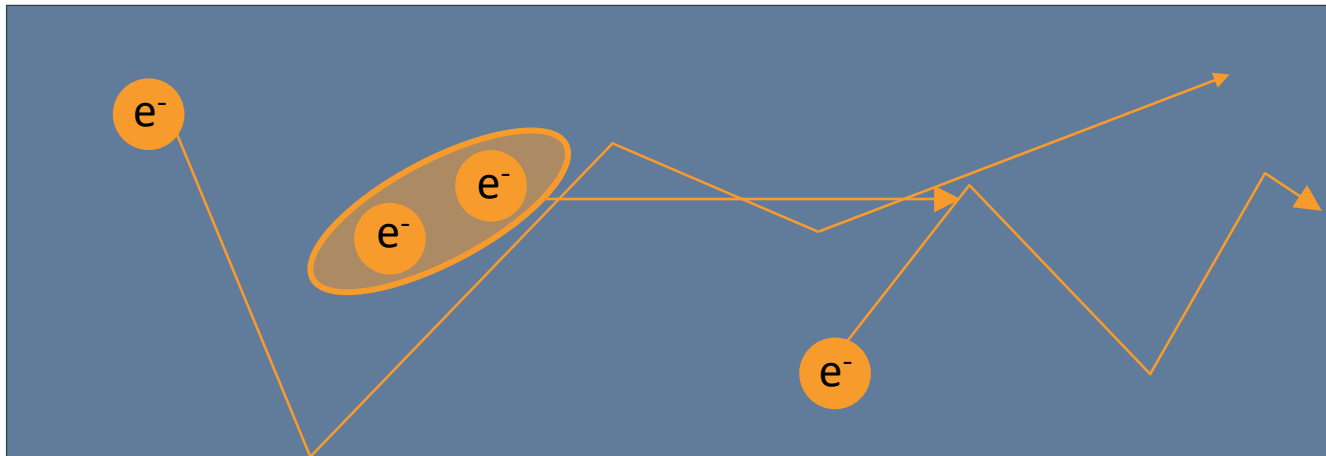

Heike Kammerlingh Onnes
October 26th, 1911

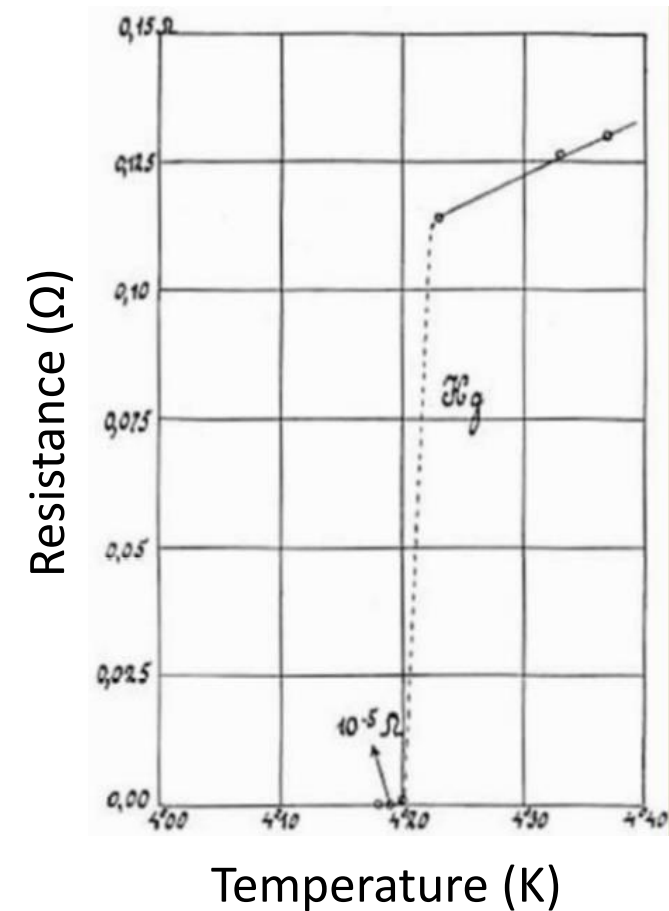

LC Oscillator & Circuits

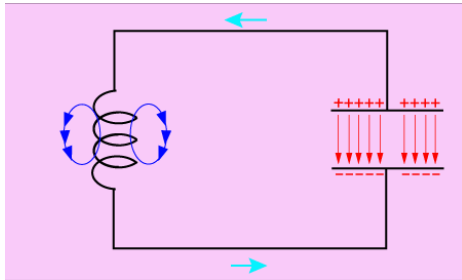

$$f_r = \frac{2\pi}{\sqrt{LC}} \rightarrow 4 \dots 10 \text{ GHz}$$

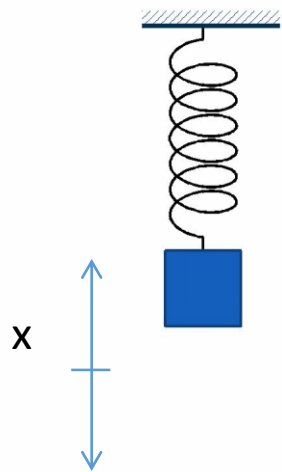

- Equidistant Energy Levels \rightarrow Cannot address only two of its states
- For QIP, need logical zero and one

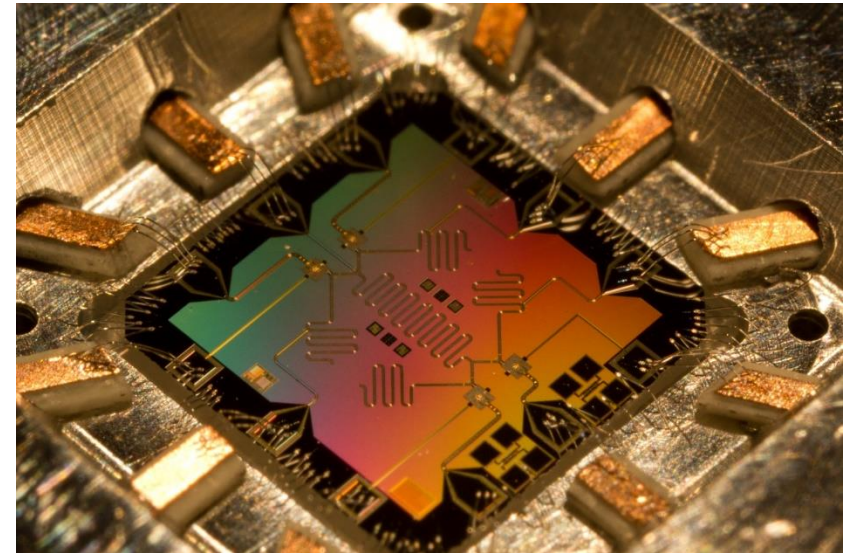

<https://web.physics.ucsb.edu/~martinisgroup/photos/BBCReZQu1103.jpg>

<https://media.giphy.com/media/EjxS2FRgJ4Hss/giphy.gif>

- Replacing the Inductor with a 'new' Element
- Qubit?

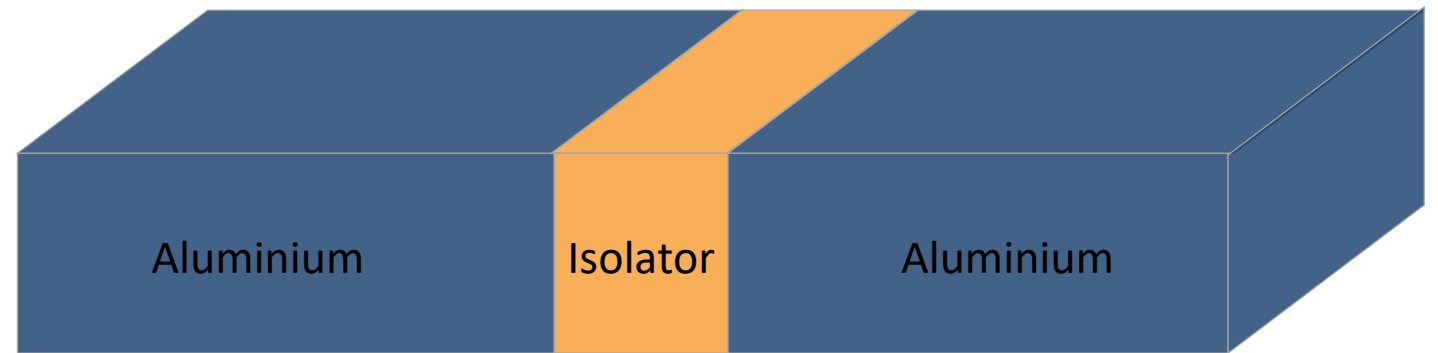
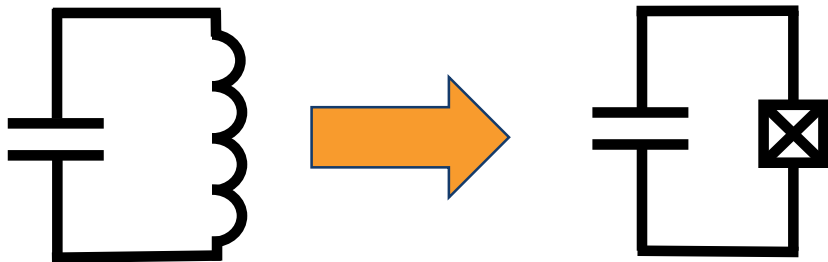

- Replacing the Inductor with a 'new' Element
- Qubit?

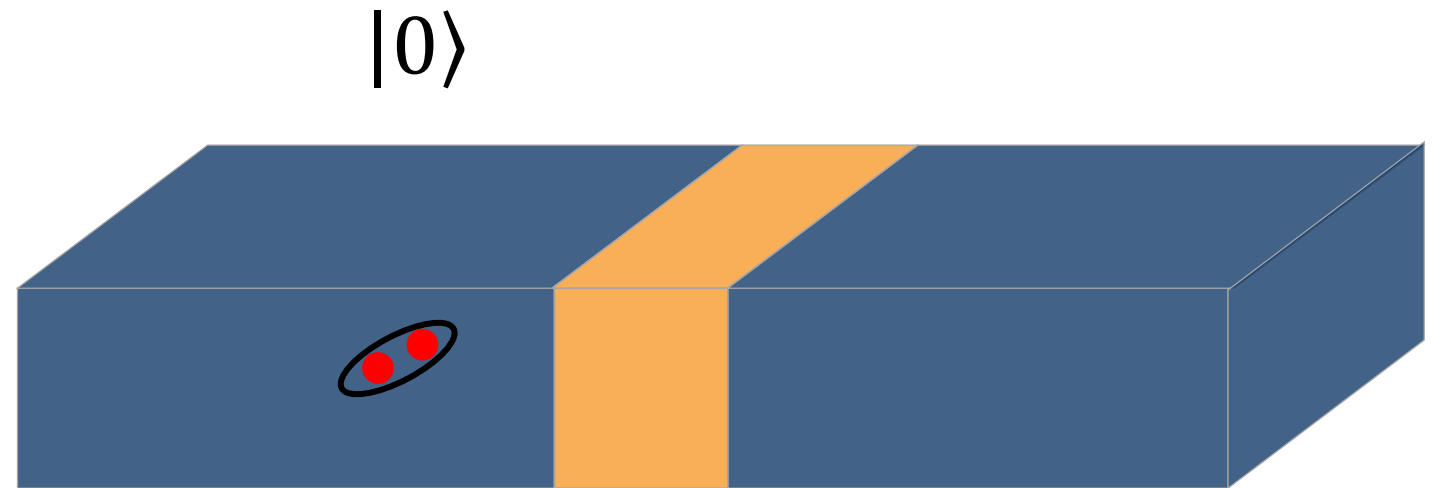
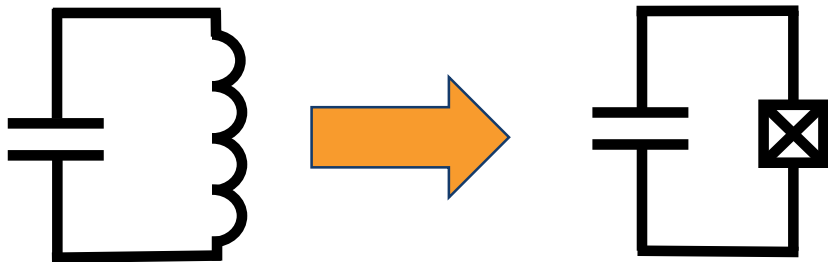

- Replacing the Inductor with a 'new' Element
- Qubit?

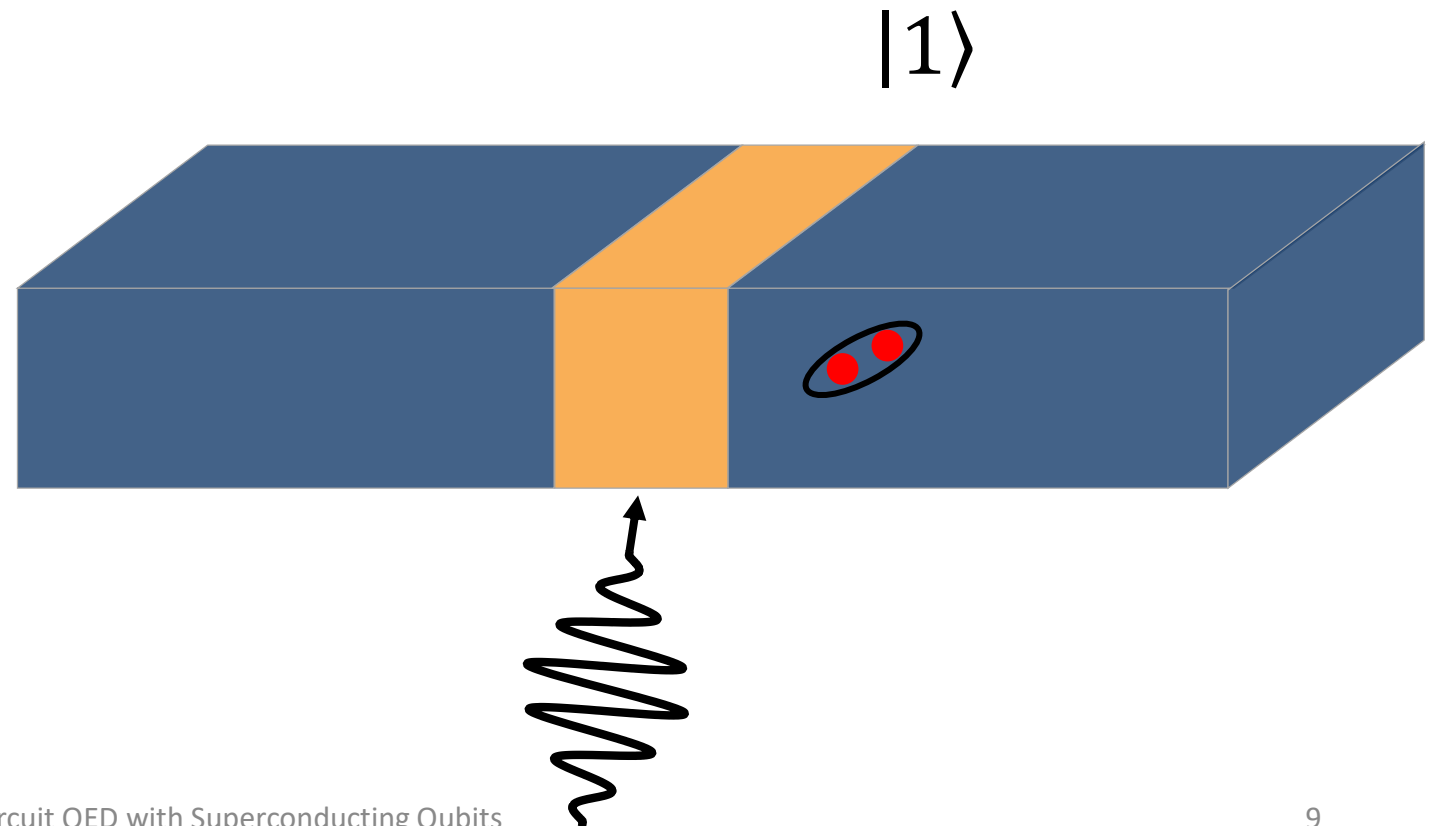
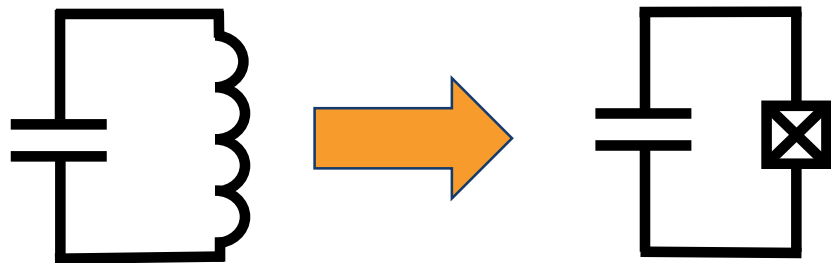

- Replacing the Inductor with a 'new' Element
- Qubit?

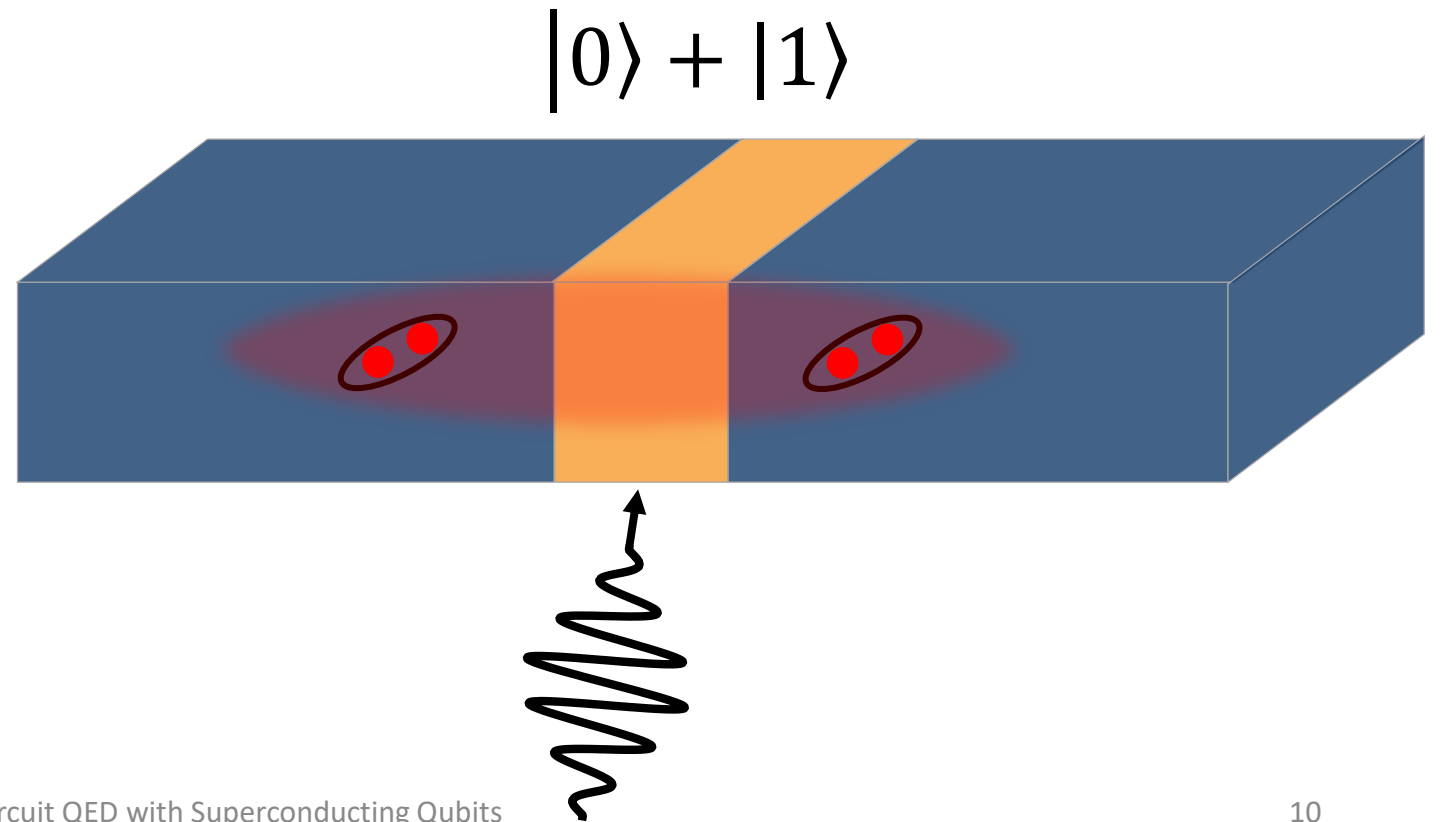
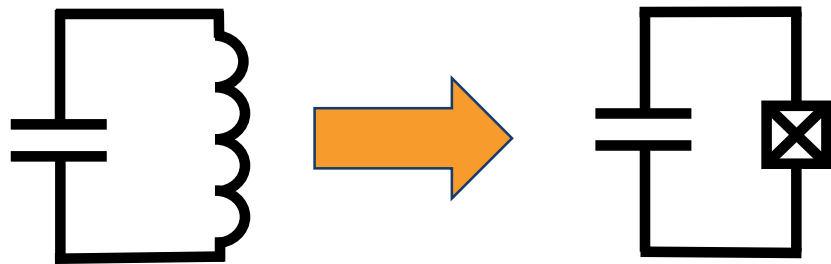

Macroscopic Atom: The Transmon Qubit

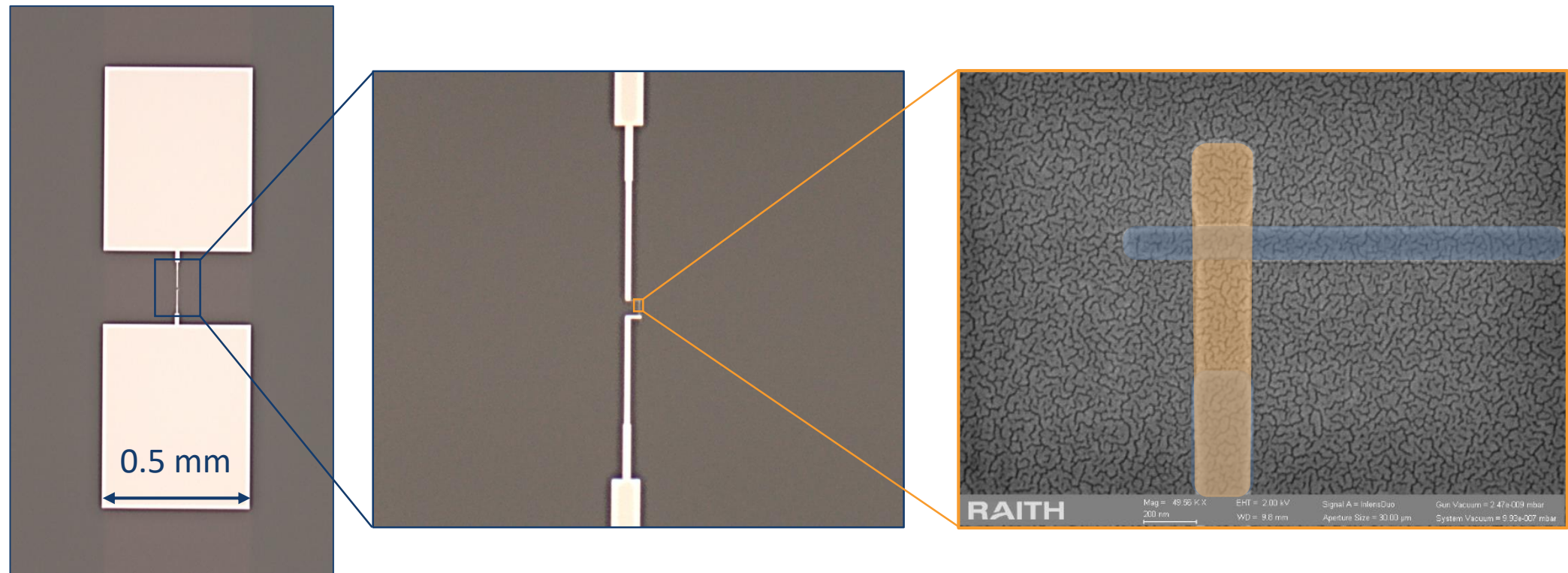
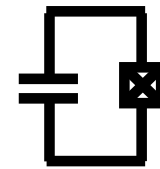

Fabrication of a Qubit

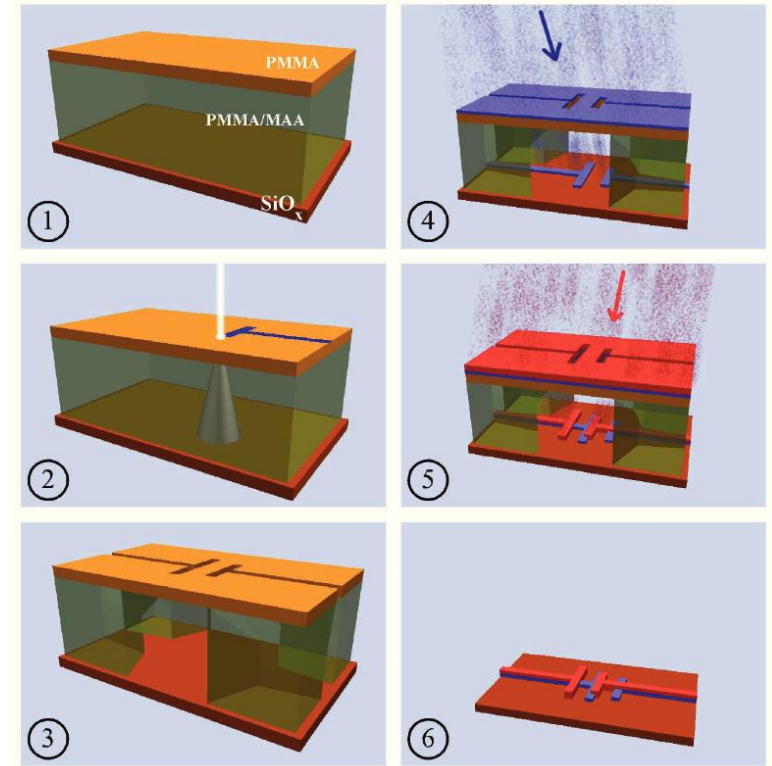

- Qubit looks like Antenna
- Need: Box to protect the Qubit

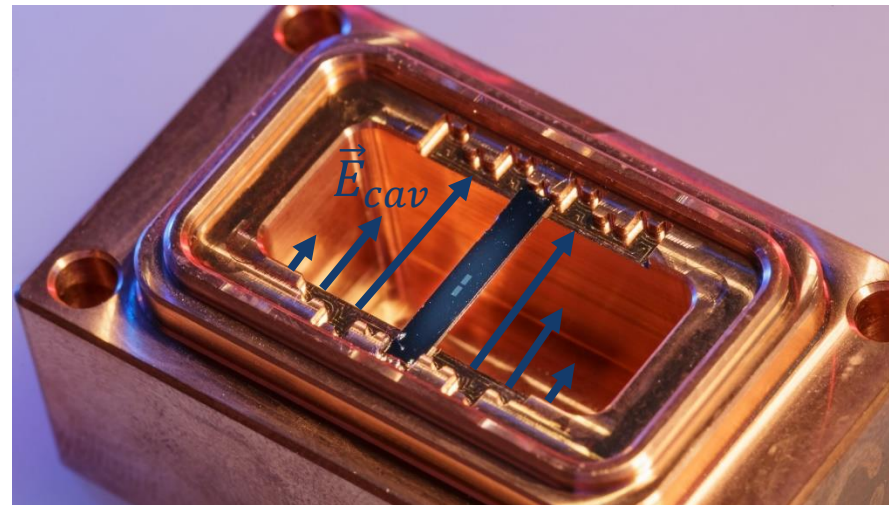
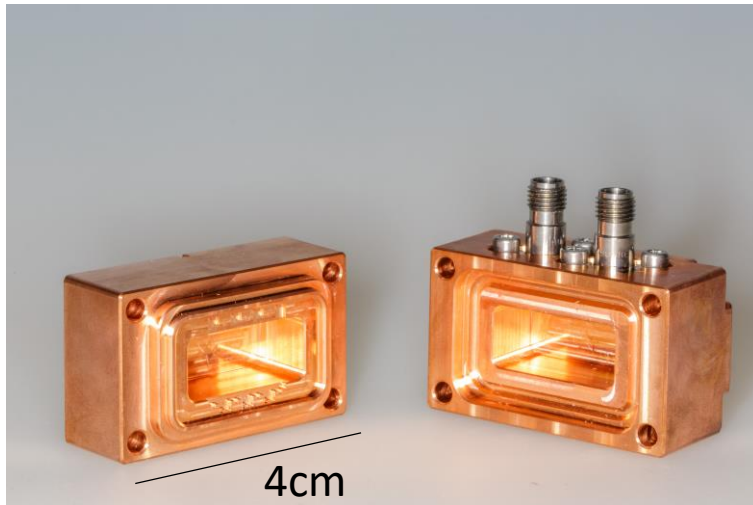

- Isolation from Environment: $f_{Qubit} \ll f_{Box}$
- Dispersive Readout
- Excitation with High Amplitude Pulse

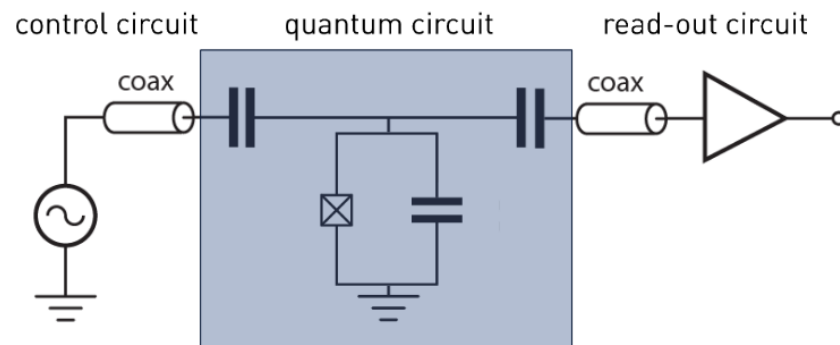

<https://arxiv.org/pdf/cond-mat/0411174.pdf>

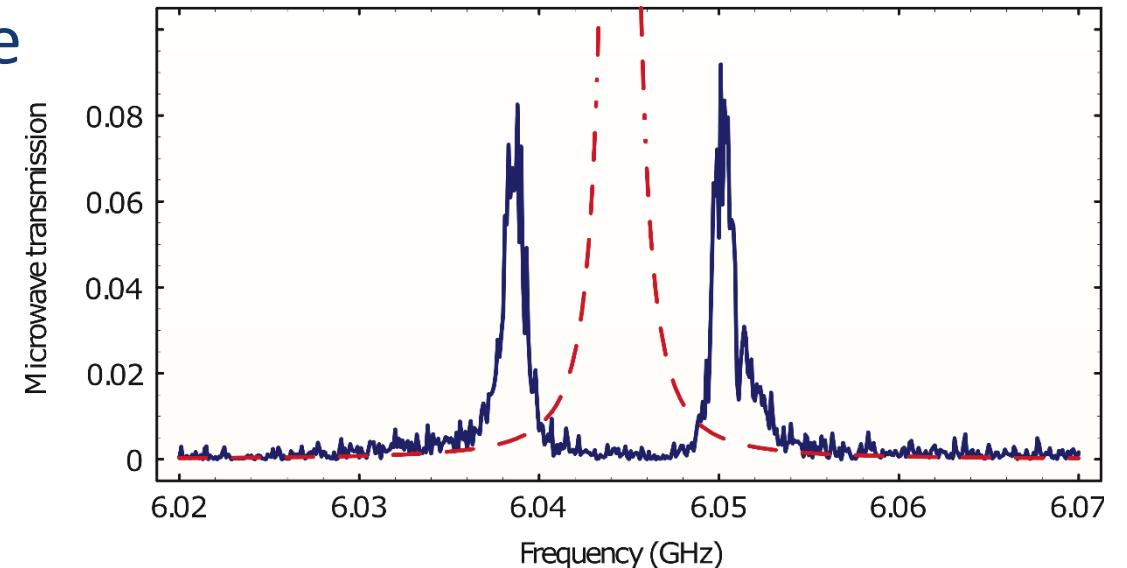

Nature **451**, 664 (2008)

The Cryostat

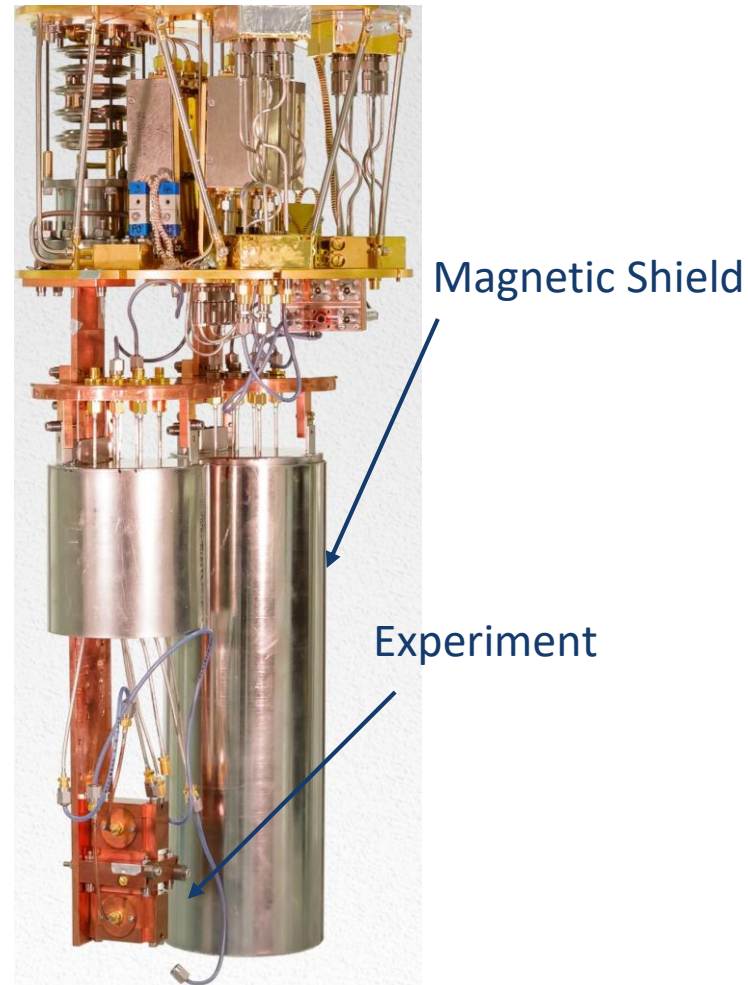
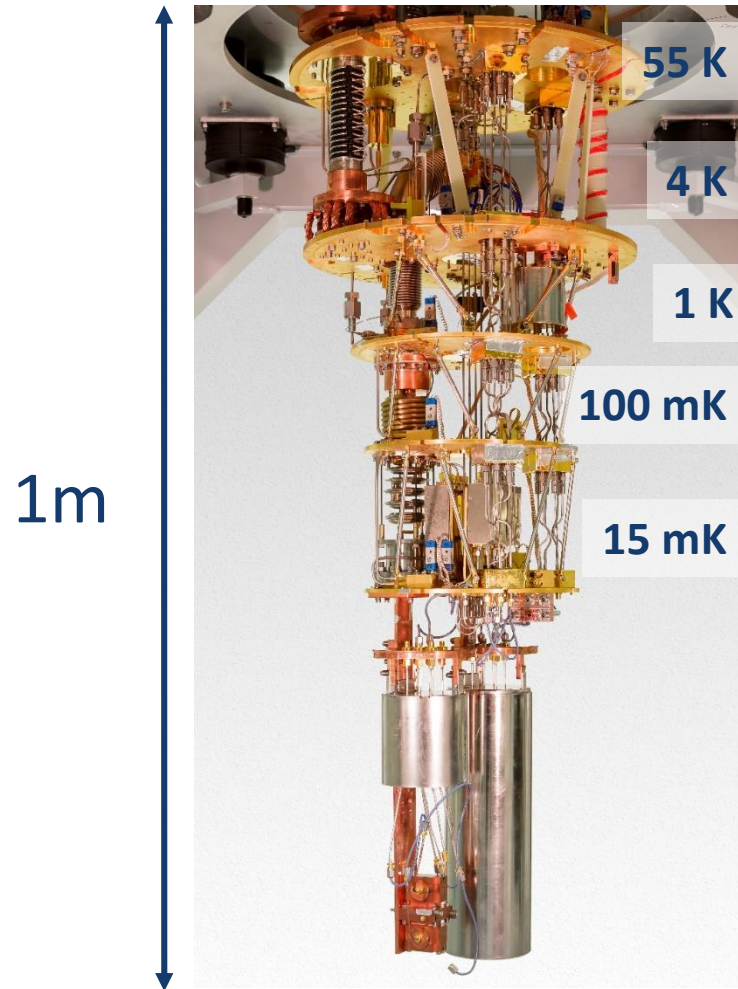

Single Qubit – Saturable Mirror

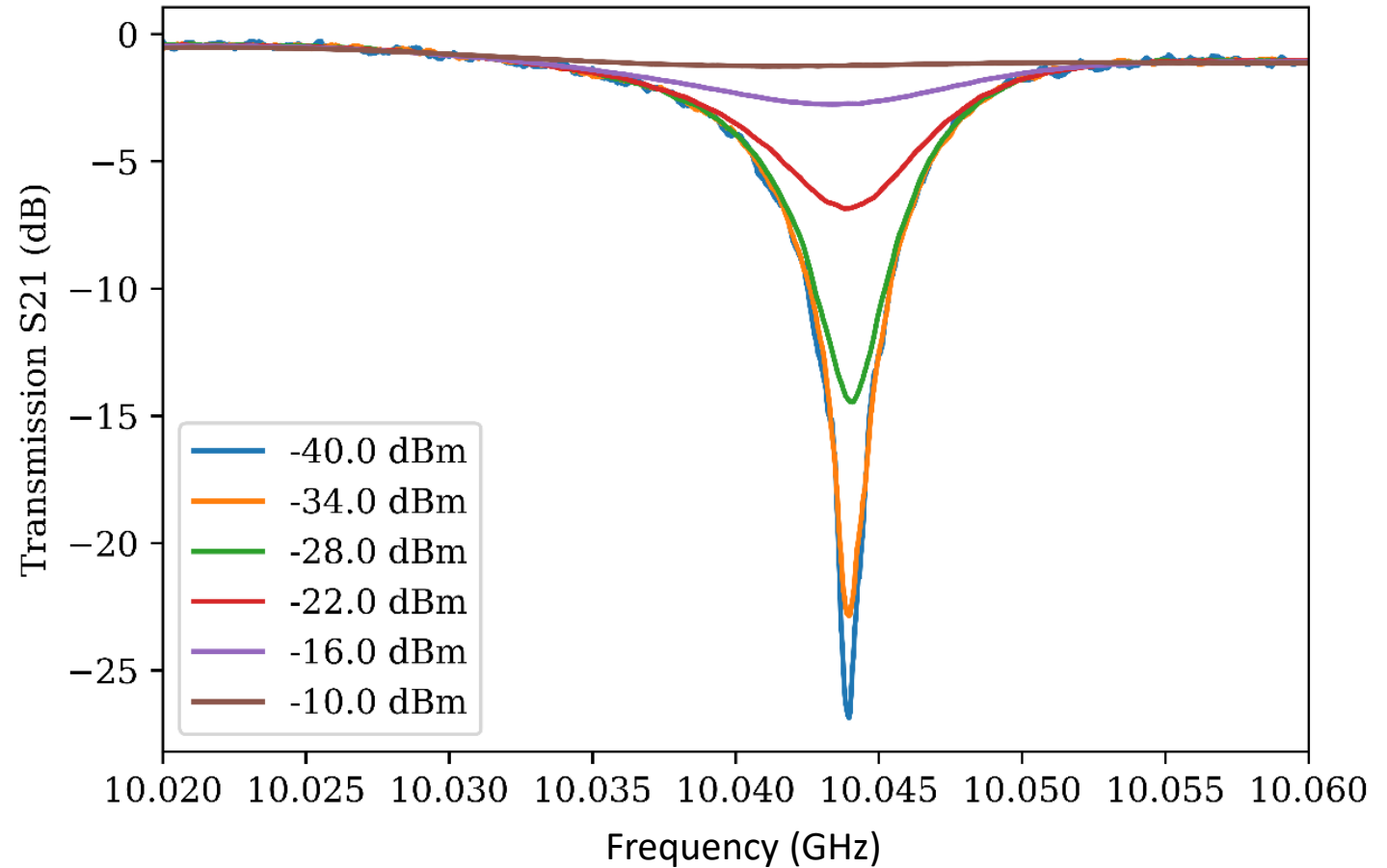
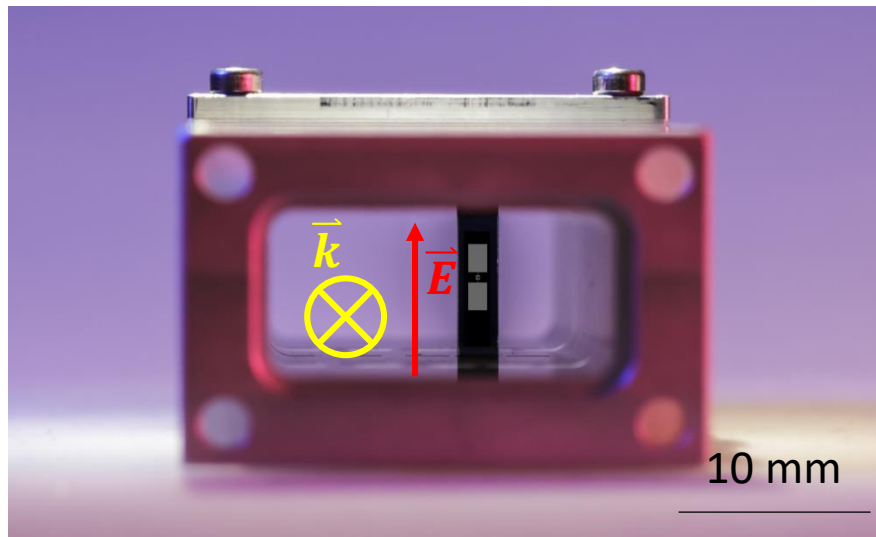

Direct Coupling

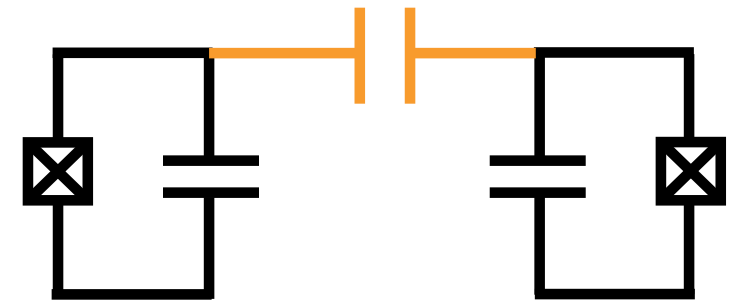
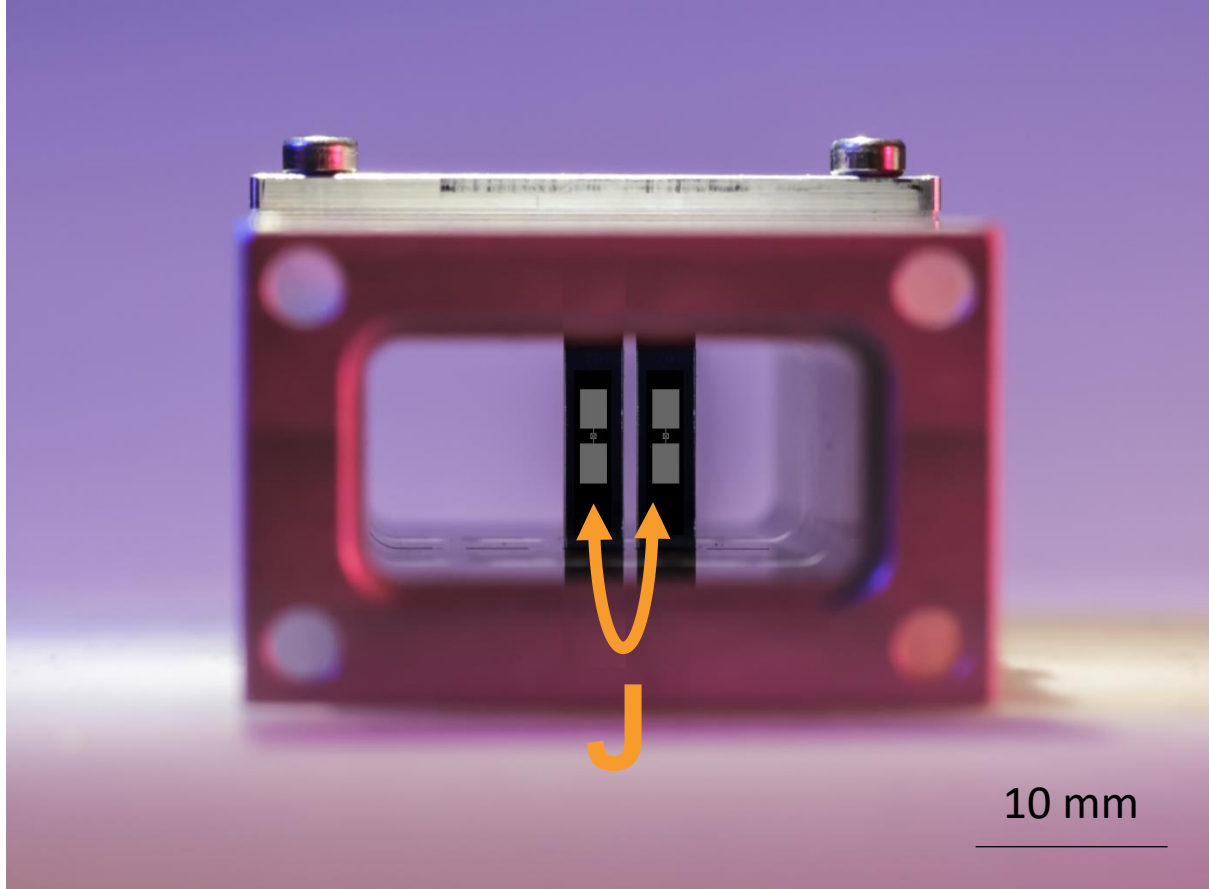

Dark State Qubit

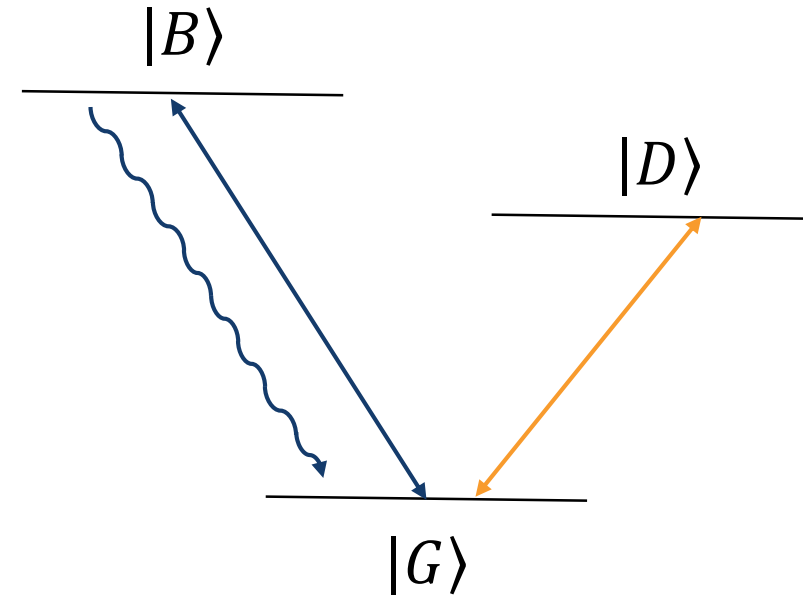
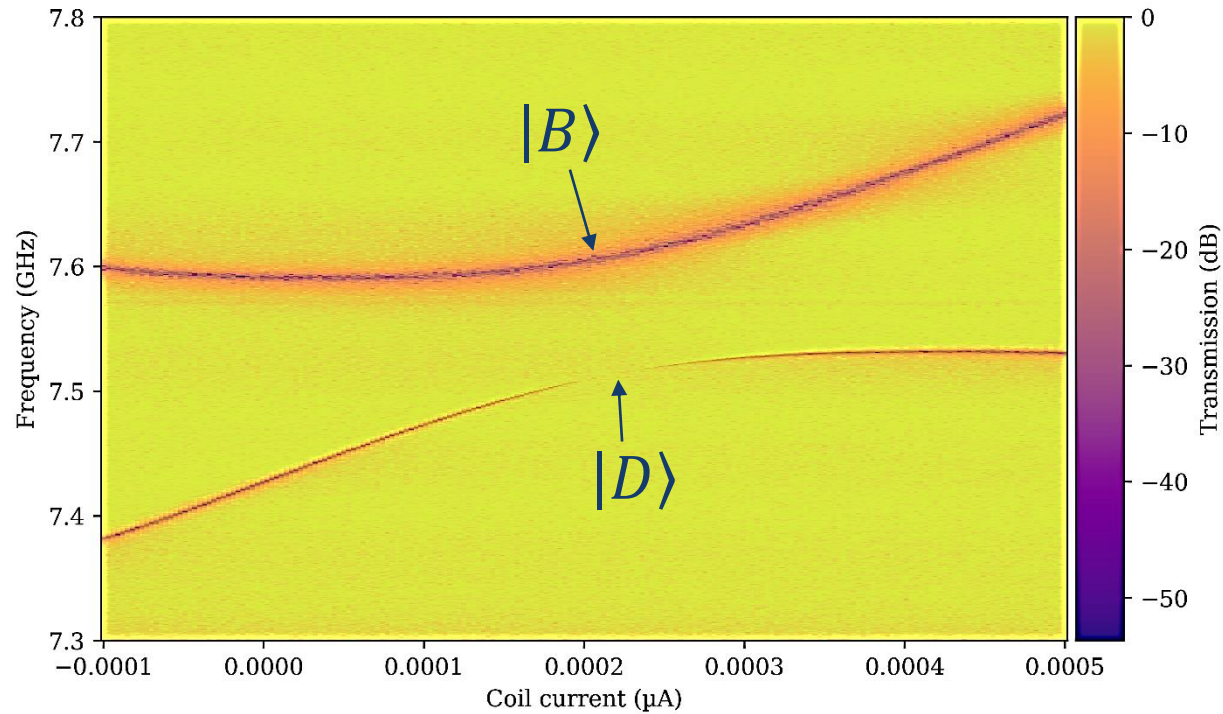

Superconducting Circuits Group

