

# Equational Termination by Semantic Labelling

Hitoshi Ohsaki<sup>1</sup>, Aart Middeldorp<sup>2</sup>, and Jürgen Giesl<sup>3</sup>

<sup>1</sup> Computer Science Division, Electrotechnical Laboratory  
Tsukuba 305-8568, Japan  
ohsaki@etl.go.jp

<sup>2</sup> Institute of Information Sciences and Electronics  
University of Tsukuba, Tsukuba 305-8573, Japan  
ami@is.tsukuba.ac.jp

<sup>3</sup> Computer Science Department  
University of New Mexico, Albuquerque, NM 87131, USA  
giesl@cs.unm.edu

**Abstract.** Semantic labelling is a powerful tool for proving termination of term rewrite systems. The usefulness of the extension to equational term rewriting described in Zantema [24] is however rather limited. In this paper we introduce a stronger version of *equational semantical labelling*, parameterized by three choices: (1) the order on the underlying algebra (partial order vs. quasi-order), (2) the relation between the algebra and the rewrite system (model vs. quasi-model), and (3) the labelling of the function symbols appearing in the equations (forbidden vs. allowed). We present soundness and completeness results for the various instantiations and analyze the relationships between them. Applications of our equational semantic labelling technique include a short proof of the main result of Ferreira *et al.* [7]—the correctness of a version of dummy elimination for AC-rewriting which completely removes the AC-axioms—and an extension of Zantema’s distribution elimination technique [23] to the equational setting.

## 1 Introduction

This paper is concerned with termination of equational term rewrite systems. Termination of ordinary term rewrite systems has been extensively studied and several powerful methods for establishing termination are available (e.g. [1, 4, 21]). For equational term rewriting much less is known, although in recent years significant progress has been made with respect to AC-termination, i.e., termination of equational rewrite systems where the set of equations consists of the associativity and commutativity axioms  $AC(f) = \{f(f(x, y), z) \approx f(x, f(y, z)), f(x, y) \approx f(y, x)\}$  for (some of) the binary function symbols occurring in the rewrite rules. An early paper on termination of equational rewriting is Jouannaud and Muñoz [11]. In that paper sufficient conditions are given for reducing termination of an equational term rewrite system to termination of its underlying term rewrite system. In another early paper (Ben Cherifa and Lescanne [2]) a characterization of the polynomials is given that can be used in a polynomial

interpretation proof of AC-termination. In more recent papers [12, 19–21] syntactic methods like the well-known recursive path order for proving termination of rewriting are extended to AC-rewriting. Marché and Urbain [14] extended the powerful dependency pair technique of Arts and Giesl [1] to AC-rewriting. In [6, 7] two extensions of dummy elimination ([8]) to equational rewriting are presented. In [15] the type introduction technique of Zantema [23] is extended to equational term rewriting.

In this paper we extend another technique of Zantema to equational term rewriting. By labelling function symbols according to the semantics of the rewrite system, semantic labelling ([24]) transforms a rewrite system into another rewrite system with the same termination behaviour. The aim is to obtain a transformed rewrite system where termination is easier to establish. The strength of semantic labelling is amply illustrated in [16, 24]. Here we present powerful extensions of semantic labelling to equational rewriting and analyze their soundness and completeness. Our equational semantic labelling yields a short correctness proof of a version of dummy elimination for AC-rewriting. This result of Ferreira *et al.* was obtained in [7] by considerably more complicated arguments. Another application of our technique is the extension of some of the results of Zantema [23] concerning distribution elimination to the AC case.

## 2 Preliminaries

Familiarity with the basics of term rewriting ([3]) is assumed. An *equational system* (ES for short) consists of a signature  $\mathcal{F}$  and a set  $\mathcal{E}$  of equations between terms in  $\mathcal{T}(\mathcal{F}, \mathcal{V})$ . We write  $s \rightarrow_{\mathcal{E}} t$  if there exist an equation  $l \approx r$  in  $\mathcal{E}$ , a substitution  $\sigma$ , and a context  $C$  such that  $s = C[l\sigma]$  and  $t = C[r\sigma]$ . The symmetric closure of  $\rightarrow_{\mathcal{E}}$  is denoted by  $\vdash_{\mathcal{E}}$  and the transitive reflexive closure of  $\vdash_{\mathcal{E}}$  by  $\sim_{\mathcal{E}}$ . A rewrite rule is an equation  $l \approx r$  such that  $l$  is not a variable and variables which occur in  $r$  also occur in  $l$ . Rewrite rules  $l \approx r$  are written as  $l \rightarrow r$ . A *term rewrite system* (TRS for short) is an ES with the property that all its equations are rewrite rules. An *equational term rewrite system* (ETRS for short)  $\mathcal{R}/\mathcal{E}$  consists of a TRS  $\mathcal{R}$  and an ES  $\mathcal{E}$  over the same signature. We write  $s \rightarrow_{\mathcal{R}/\mathcal{E}} t$  if there exist terms  $s'$  and  $t'$  such that  $s \sim_{\mathcal{E}} s' \rightarrow_{\mathcal{R}} t' \sim_{\mathcal{E}} t$ . Similar to ordinary term rewrite systems, an ETRS is called *terminating* if there does not exist an infinite  $\rightarrow_{\mathcal{R}/\mathcal{E}}$  reduction.

Let  $\mathcal{F}$  be a signature and  $\mathcal{A} = (A, \{f_{\mathcal{A}}\}_{f \in \mathcal{F}})$  an  $\mathcal{F}$ -algebra equipped with a quasi-order (i.e., a reflexive and transitive relation)  $\succsim$  on its (non-empty) carrier  $A$ . For any variable assignment  $\alpha: \mathcal{V} \rightarrow A$  we define the term evaluation  $[\alpha]_{\mathcal{A}}: \mathcal{T}(\mathcal{F}, \mathcal{V}) \rightarrow A$  inductively by  $[\alpha]_{\mathcal{A}}(x) = \alpha(x)$  and  $[\alpha]_{\mathcal{A}}(f(t_1, \dots, t_n)) = f_{\mathcal{A}}([\alpha]_{\mathcal{A}}(t_1), \dots, [\alpha]_{\mathcal{A}}(t_n))$  for  $x \in \mathcal{V}$ ,  $f \in \mathcal{F}$ , and  $t_1, \dots, t_n \in \mathcal{T}(\mathcal{F}, \mathcal{V})$ . If  $\mathcal{A}$  is clear from the context, then we often write  $[\alpha]$  instead of  $[\alpha]_{\mathcal{A}}$ . We say that  $\mathcal{A}$  is *monotone* if the algebra operations of  $\mathcal{A}$  are monotone with respect to  $\succsim$  in all coordinates, i.e., if  $f \in \mathcal{F}$  has arity  $n \geq 1$  then  $f_{\mathcal{A}}(a_1, \dots, a_i, \dots, a_n) \succsim f_{\mathcal{A}}(a_1, \dots, b, \dots, a_n)$  for all  $a_1, \dots, a_n, b \in A$  and  $i \in \{1, \dots, n\}$  with  $a_i \succsim b$ . An ETRS  $\mathcal{R}/\mathcal{E}$  over a signature  $\mathcal{F}$  is *compatible* with a monotone  $\mathcal{F}$ -algebra

$(\mathcal{A}, \succsim)$  if  $l \succsim_{\mathcal{A}} r$  for every rewrite rule  $l \rightarrow r \in \mathcal{R}$  and  $l \sim_{\mathcal{A}} r$  for every equation  $l \approx r \in \mathcal{E}$ . Here the relation  $\succsim_{\mathcal{A}}$  is defined by  $s \succsim_{\mathcal{A}} t$  if  $[\alpha]_{\mathcal{A}}(s) \succsim [\alpha]_{\mathcal{A}}(t)$  for every assignment  $\alpha$  and  $\sim_{\mathcal{A}}$  is the equivalence relation induced by  $\succsim_{\mathcal{A}}$ . If  $\mathcal{R}/\mathcal{E}$  and  $(\mathcal{A}, \succsim)$  are compatible, we also say that  $(\mathcal{A}, \succsim)$  is a *quasi-model* of  $\mathcal{R}/\mathcal{E}$ . We call  $(\mathcal{A}, \succsim)$  a *model* of  $\mathcal{R}/\mathcal{E}$  if  $l \sim_{\mathcal{A}} r$  for all  $l \rightarrow r \in \mathcal{R}$  and  $l \approx r \in \mathcal{E}$ .

A TRS  $\mathcal{R}$  is *precedence terminating* if there exists a well-founded order  $\sqsupset$  on its signature  $\mathcal{F}$  such that  $\text{root}(l) \sqsupset f$  for every rule  $l \rightarrow r \in \mathcal{R}$  and every function symbol  $f$  occurring in  $r$ . Precedence terminating TRSs are terminating ([16]). The next lemma states that this remains true in the presence of AC-axioms.

**Lemma 1.** *Let  $\mathcal{R}/\mathcal{E}$  be an ETRS over a signature  $\mathcal{F}$  such that  $\mathcal{E} = \bigcup_{f \in \mathcal{G}} \text{AC}(f)$  for some subset  $\mathcal{G}$  of  $\mathcal{F}$ . If  $\mathcal{R}$  is precedence terminating then  $\mathcal{R}/\mathcal{E}$  is terminating.*

*Proof.* By definition there is a well-founded order  $\sqsupset$  on  $\mathcal{F}$  such that  $\text{root}(l) \sqsupset f$  for every rule  $l \rightarrow r \in \mathcal{R}$  and every function symbol  $f$  occurring in  $r$ . Any AC-compatible recursive path order induced by  $\sqsupset$  that is defined on terms with variables (e.g. [13, 19]) orients the rules of  $\mathcal{R}$  from left to right. (The complicated case in which two terms with equal root symbols in  $\mathcal{G}$  have to be compared never arises due to the assumption on  $\sqsupset$ .) We conclude that  $\mathcal{R}/\mathcal{E}$  is terminating.  $\square$

### 3 Semantic Labelling for Equational Rewriting

In this section we present our equational semantic labelling framework by appropriately extending the definitions of Zantema [24] for ordinary semantic labelling.

**Definition 1.** *Let  $\mathcal{F}$  be a signature and  $\mathcal{A}$  an  $\mathcal{F}$ -algebra. A labelling  $L$  for  $\mathcal{F}$  consists of sets of labels  $L_f \subseteq A$  for every  $f \in \mathcal{F}$ . The labelled signature  $\mathcal{F}_{\text{lab}}$  consists of  $n$ -ary function symbols  $f_a$  for every  $n$ -ary function symbol  $f \in \mathcal{F}$  and label  $a \in L_f$  together with all function symbols  $f \in \mathcal{F}$  such that  $L_f = \emptyset$ . A labelling  $\ell$  for  $\mathcal{A}$  consists of a labelling  $L$  for the signature  $\mathcal{F}$  together with mappings  $\ell_f: A^n \rightarrow L_f$  for every  $n$ -ary function symbol  $f \in \mathcal{F}$  with  $L_f \neq \emptyset$ . If  $\mathcal{A}$  is equipped with a quasi-order  $\succsim$  then the labelling is said to be *monotone* if its labelling functions  $\ell_f$  are monotone (with respect to  $\succsim$ ) in all arguments.*

**Definition 2.** *Let  $\mathcal{R}/\mathcal{E}$  be an ETRS over a signature  $\mathcal{F}$ ,  $(\mathcal{A}, \succsim)$  an  $\mathcal{F}$ -algebra, and  $\ell$  a labelling for  $\mathcal{A}$ . For every assignment  $\alpha$  we inductively define a labelling function  $\text{lab}_{\alpha}$  from  $\mathcal{T}(\mathcal{F}, \mathcal{V})$  to  $\mathcal{T}(\mathcal{F}_{\text{lab}}, \mathcal{V})$ :  $\text{lab}_{\alpha}(t) = t$  if  $t \in \mathcal{V}$  and  $\text{lab}_{\alpha}(t) = f_{\ell_f([\alpha](t_1), \dots, [\alpha](t_n))}(\text{lab}_{\alpha}(t_1), \dots, \text{lab}_{\alpha}(t_n))$  if  $t = f(t_1, \dots, t_n)$ . We define TRSs  $\mathcal{R}_{\text{lab}}$ ,  $\text{Dec}(\mathcal{F}, \succ)$  and ESs  $\mathcal{E}_{\text{lab}}$ ,  $\text{Eq}(\mathcal{F}, \sim)$  over the signature  $\mathcal{F}_{\text{lab}}$  as follows:*

$$\mathcal{R}_{\text{lab}} = \{ \text{lab}_{\alpha}(l) \rightarrow \text{lab}_{\alpha}(r) \mid l \rightarrow r \in \mathcal{R} \text{ and } \alpha: \mathcal{V} \rightarrow A \},$$

$$\mathcal{E}_{\text{lab}} = \{ \text{lab}_{\alpha}(l) \approx \text{lab}_{\alpha}(r) \mid l \approx r \in \mathcal{E} \text{ and } \alpha: \mathcal{V} \rightarrow A \},$$

$$\text{Dec}(\mathcal{F}, \succ) = \{ f_a(x_1, \dots, x_n) \rightarrow f_b(x_1, \dots, x_n) \mid f \in \mathcal{F}, a, b \in L_f, a \succ b \},$$

$$\text{Eq}(\mathcal{F}, \sim) = \{ f_a(x_1, \dots, x_n) \approx f_b(x_1, \dots, x_n) \mid f \in \mathcal{F}, a, b \in L_f, a \sim b, a \neq b \}.$$

*The purpose of the condition  $a \neq b$  in the definition of  $\text{Eq}(\mathcal{F}, \sim)$  is to exclude trivial equations. When the signature  $\mathcal{F}$  and the quasi-order  $\succsim$  can be inferred from the context we just write  $\text{Dec}$  and  $\text{Eq}$ . We write  $\bar{\mathcal{R}}$  for the union of  $\mathcal{R}_{\text{lab}}$*

and Dec and  $\bar{\mathcal{E}}$  for the union of  $\mathcal{E}_{\text{lab}}$  and Eq.

The next theorem states our first equational semantic labelling result.

**Theorem 1.** *Let  $\mathcal{R}/\mathcal{E}$  be an ETRS over a signature  $\mathcal{F}$ ,  $(\mathcal{A}, \succsim)$  a monotone  $\mathcal{F}$ -algebra, and  $\ell$  a monotone labelling for  $\mathcal{A}$ . If  $\mathcal{A}$  is a quasi-model of  $\mathcal{R}/\mathcal{E}$  and  $\bar{\mathcal{R}}/\bar{\mathcal{E}}$  is terminating then  $\mathcal{R}/\mathcal{E}$  is terminating.*

*Proof.* We show that for all terms  $s, t \in \mathcal{T}(\mathcal{F}, \mathcal{V})$  and assignments  $\alpha$  we have

1. if  $s \rightarrow_{\mathcal{R}} t$  then  $\text{lab}_{\alpha}(s) \sim_{\bar{\mathcal{E}}} \cdot \xrightarrow{\bar{\mathcal{R}}} \text{lab}_{\alpha}(t)$ ,
2. if  $s \vdash_{\mathcal{E}} t$  then  $\text{lab}_{\alpha}(s) \sim_{\bar{\mathcal{E}}} \text{lab}_{\alpha}(t)$ .

Suppose  $s = C[l\sigma]$  and  $t = C[r\sigma]$  for some rewrite rule  $l \rightarrow r \in \mathcal{R}$ , context  $C$ , and substitution  $\sigma$ . We show (1) by induction on  $C$ . If  $C = \square$  then  $\text{lab}_{\alpha}(s) = \text{lab}_{\alpha}(l\sigma)$  and  $\text{lab}_{\alpha}(t) = \text{lab}_{\alpha}(r\sigma)$ . Define the assignment  $\beta = [\alpha]_{\mathcal{A}} \circ \sigma$  and the substitution  $\tau = \text{lab}_{\alpha} \circ \sigma$  (i.e.,  $\sigma$  is applied first). An easy induction proof (e.g. [23, Lemma 2]) reveals that  $\text{lab}_{\alpha}(l\sigma) = \text{lab}_{\beta}(l)\tau$  and  $\text{lab}_{\alpha}(r\sigma) = \text{lab}_{\beta}(r)\tau$ . By definition  $\text{lab}_{\beta}(l) \rightarrow \text{lab}_{\beta}(r) \in \mathcal{R}_{\text{lab}}$  and hence  $\text{lab}_{\alpha}(s) = \text{lab}_{\beta}(l)\tau \rightarrow_{\mathcal{R}_{\text{lab}}} \text{lab}_{\beta}(r)\tau = \text{lab}_{\alpha}(t)$ . For the induction step, let  $C = f(u_1, \dots, C', \dots, u_n)$ . The induction hypothesis yields  $\text{lab}_{\alpha}(C'[l\sigma]) \sim_{\bar{\mathcal{E}}} \cdot \xrightarrow{\bar{\mathcal{R}}} \text{lab}_{\alpha}(C'[r\sigma])$ . Because  $\mathcal{A}$  is a quasi-model of  $\mathcal{R}/\mathcal{E}$  and  $C'[l\sigma] \rightarrow_{\mathcal{R}} C'[r\sigma]$ , we have  $[\alpha]_{\mathcal{A}}(C'[l\sigma]) \succsim [\alpha]_{\mathcal{A}}(C'[r\sigma])$ . Let

$$a = \ell_f([\alpha]_{\mathcal{A}}(u_1), \dots, [\alpha]_{\mathcal{A}}(C'[l\sigma]), \dots, [\alpha]_{\mathcal{A}}(u_n))$$

and

$$b = \ell_f([\alpha]_{\mathcal{A}}(u_1), \dots, [\alpha]_{\mathcal{A}}(C'[r\sigma]), \dots, [\alpha]_{\mathcal{A}}(u_n)).$$

Monotonicity of the labelling function  $\ell_f$  yields  $a \succsim b$ . We distinguish two cases. If  $a \succ b$  then

$$\begin{aligned} \text{lab}_{\alpha}(s) &\sim_{\bar{\mathcal{E}}} \cdot \xrightarrow{\bar{\mathcal{R}}} f_a(\text{lab}_{\alpha}(u_1), \dots, \text{lab}_{\alpha}(C'[r\sigma]), \dots, \text{lab}_{\alpha}(u_n)) \\ &\xrightarrow{\text{Dec}} f_b(\text{lab}_{\alpha}(u_1), \dots, \text{lab}_{\alpha}(C'[r\sigma]), \dots, \text{lab}_{\alpha}(u_n)) \\ &= \text{lab}_{\alpha}(t). \end{aligned}$$

If  $a \sim b$  then

$$\begin{aligned} \text{lab}_{\alpha}(s) &\vdash_{\text{Eq}} f_b(\text{lab}_{\alpha}(u_1), \dots, \text{lab}_{\alpha}(C'[l\sigma]), \dots, \text{lab}_{\alpha}(u_n)) \\ &\sim_{\bar{\mathcal{E}}} \cdot \xrightarrow{\bar{\mathcal{R}}} f_b(\text{lab}_{\alpha}(u_1), \dots, \text{lab}_{\alpha}(C'[r\sigma]), \dots, \text{lab}_{\alpha}(u_n)) \\ &= \text{lab}_{\alpha}(t). \end{aligned}$$

Here  $\vdash_{\text{Eq}}^{\bar{\mathcal{E}}}$  denotes  $\vdash_{\text{Eq}} \cup =$ . Since  $\sim_{\bar{\mathcal{E}}} \cdot \xrightarrow{\bar{\mathcal{R}}} \cdot \xrightarrow{\text{Dec}} \subseteq \sim_{\bar{\mathcal{E}}} \cdot \xrightarrow{\bar{\mathcal{R}}}$  and  $\vdash_{\text{Eq}}^{\bar{\mathcal{E}}} \cdot \sim_{\bar{\mathcal{E}}} \cdot \xrightarrow{\bar{\mathcal{R}}} \subseteq \sim_{\bar{\mathcal{E}}} \cdot \xrightarrow{\bar{\mathcal{R}}}$ , in both cases we obtain the desired  $\text{lab}_{\alpha}(s) \sim_{\bar{\mathcal{E}}} \cdot \xrightarrow{\bar{\mathcal{R}}} \text{lab}_{\alpha}(t)$ .

The proof of (2) follows along the same lines. In the induction step we have  $[\alpha]_{\mathcal{A}}(C'[l\sigma]) \sim [\alpha]_{\mathcal{A}}(C'[r\sigma])$ . Monotonicity of  $\ell_f$  yields both  $a \succsim b$  and  $b \succsim a$ . Hence  $a \sim b$  and thus

$$\begin{aligned} \text{lab}_{\alpha}(s) &= f_a(\text{lab}_{\alpha}(u_1), \dots, \text{lab}_{\alpha}(C'[l\sigma]), \dots, \text{lab}_{\alpha}(u_n)) \\ &\vdash_{\text{Eq}}^{\bar{\mathcal{E}}} f_b(\text{lab}_{\alpha}(u_1), \dots, \text{lab}_{\alpha}(C'[l\sigma]), \dots, \text{lab}_{\alpha}(u_n)) \\ &\sim_{\bar{\mathcal{E}}} f_b(\text{lab}_{\alpha}(u_1), \dots, \text{lab}_{\alpha}(C'[r\sigma]), \dots, \text{lab}_{\alpha}(u_n)) \\ &= \text{lab}_{\alpha}(t) \end{aligned}$$

by the definition of Eq and the induction hypothesis.

From (1) and (2) it follows that any infinite  $\mathcal{R}/\mathcal{E}$ -rewrite sequence gives rise to an infinite  $\bar{\mathcal{R}}/\bar{\mathcal{E}}$ -rewrite sequence.  $\square$

The converse of the above theorem does not hold. Consider the terminating ETRS  $\mathcal{R}/\mathcal{E}$  with  $\mathcal{R} = \emptyset$  and  $\mathcal{E} = \{f(\mathbf{a}) \approx \mathbf{a}\}$ . Let  $\mathcal{A}$  be the algebra over the carrier  $\{0, 1\}$  with  $1 \succ 0$  and operations  $f_{\mathcal{A}}(x) = x$  for all  $x \in \{0, 1\}$  and  $\mathbf{a}_{\mathcal{A}} = 1$ . Note that  $\mathcal{A}$  is a (quasi-)model of  $\mathcal{R}/\mathcal{E}$ . By letting  $\ell_f$  be the identity function and by choosing  $L_{\mathbf{a}} = \emptyset$ , we obtain the labelled ETRS  $\overline{\mathcal{R}}/\overline{\mathcal{E}}$  with  $\mathcal{R}_{\text{lab}} = \emptyset$ ,  $\text{Dec} = \{f_1(x) \rightarrow f_0(x)\}$ ,  $\mathcal{E}_{\text{lab}} = \{f_1(\mathbf{a}) \approx \mathbf{a}\}$ , and  $\text{Eq} = \emptyset$ . The ETRS  $\overline{\mathcal{R}}/\overline{\mathcal{E}}$  is not terminating:  $\mathbf{a} \sim_{\mathcal{E}_{\text{lab}}} f_1(\mathbf{a}) \rightarrow_{\text{Dec}} f_0(\mathbf{a}) \sim_{\mathcal{E}_{\text{lab}}} f_0(f_1(\mathbf{a})) \rightarrow_{\text{Dec}} \dots$ . Nevertheless, in this example there are no infinite  $\overline{\mathcal{R}}/\overline{\mathcal{E}}$ -rewrite sequences that contain infinitely many  $\mathcal{R}_{\text{lab}}/\overline{\mathcal{E}}$ -steps, which is known as the *relative termination* (Geser [10]) of  $\mathcal{R}_{\text{lab}}/\overline{\mathcal{E}}$  with respect to Dec. It is not difficult to show that under the assumptions of Theorem 1 termination of  $\mathcal{R}/\mathcal{E}$  is equivalent to relative termination of  $\mathcal{R}_{\text{lab}}/\overline{\mathcal{E}}$  with respect to Dec.

Zanema [24] showed the necessity of the inclusion of Dec in  $\overline{\mathcal{R}}$  for the correctness of Theorem 1 (with  $\mathcal{E} = \emptyset$ ) by means of the TRS  $\mathcal{R} = \{f(g(x)) \rightarrow g(g(f(x)))\}$ , the algebra  $\mathcal{A}$  over the carrier  $\{0, 1\}$  with operations  $f_{\mathcal{A}}(x) = 1$  and  $g_{\mathcal{A}}(x) = 0$  for all  $x \in \{0, 1\}$ , and the order  $1 \succ 0$ . By labelling  $f$  with the value of its argument, we obtain the TRS  $\mathcal{R}_{\text{lab}} = \{f_0(g(x)) \rightarrow g(g(f_1(f_0(x))))\}$ ,  $f_0(g(x)) \rightarrow g(g(f_1(f_1(x))))\}$  which is compatible with the recursive path order with precedence  $f_0 \sqsupset f_1, g$ . However,  $\mathcal{R}$  is not terminating:  $f(f(g(x))) \rightarrow f(g(g(f(x)))) \rightarrow g(g(f(f(g(x)))))) \rightarrow \dots$

The inclusion of Eq in  $\overline{\mathcal{E}}$  is also essential for the correctness of Theorem 1. Consider the ETRS  $\mathcal{R}/\mathcal{E}$  with  $\mathcal{R} = \{f(\mathbf{a}, \mathbf{b}, x) \rightarrow f(x, x, x), g(x, y) \rightarrow x, g(x, y) \rightarrow y\}$  and  $\mathcal{E} = \emptyset$ . Let  $\mathcal{A}$  be the algebra over the carrier  $\{0, 1\}$  with  $0 \sim 1$  and operations  $f_{\mathcal{A}}(x, y, z) = 1$ ,  $g_{\mathcal{A}}(x, y) = 0$ ,  $\mathbf{a}_{\mathcal{A}} = 0$ , and  $\mathbf{b}_{\mathcal{A}} = 1$ . We label function symbol  $f$  as follows:  $\ell_f(x, y, z) = 0$  if  $x = y$  and  $\ell_f(x, y, z) = 1$  if  $x \neq y$ . Note that  $\mathcal{A}$  is a quasi-model for  $\mathcal{R}/\mathcal{E}$  and  $\ell_f$  is trivially monotone. We have  $\mathcal{R}_{\text{lab}} = \{f_1(\mathbf{a}, \mathbf{b}, x) \rightarrow f_0(x, x, x), g(x, y) \rightarrow x, g(x, y) \rightarrow y\}$ ,  $\text{Dec} = \emptyset$ , and  $\mathcal{E}_{\text{lab}} = \emptyset$ . Termination of  $\overline{\mathcal{R}}$  is easily shown. It is well-known (Toyama [22]) that  $\mathcal{R}$  is not terminating. Note that in this example  $\text{Eq} = \{f_0(x, y, z) \approx f_1(x, y, z)\}$  and hence  $\overline{\mathcal{R}}/\overline{\mathcal{E}}$  is not terminating.

Finally, both monotonicity requirements are essential. Consider the TRS  $\mathcal{R} = \{f(g(\mathbf{a})) \rightarrow f(g(\mathbf{b})), \mathbf{b} \rightarrow \mathbf{a}\}$ . Let  $\mathcal{A}$  be the algebra over the carrier  $\{0, 1\}$  with  $1 \succ 0$  and operations  $f_{\mathcal{A}}(x) = 0$ ,  $g_{\mathcal{A}}(x) = 1 - x$ ,  $\mathbf{a}_{\mathcal{A}} = 0$ , and  $\mathbf{b}_{\mathcal{A}} = 1$ . We have  $l \succ_{\mathcal{A}} r$  for both rules  $l \rightarrow r \in \mathcal{R}$ . If  $\ell_f(x) = x$  then we obtain the TRS  $\overline{\mathcal{R}} = \{f_1(g(\mathbf{a})) \rightarrow f_0(g(\mathbf{b})), \mathbf{b} \rightarrow \mathbf{a}, f_1(x) \rightarrow f_0(x)\}$  which is compatible with the recursive path order with precedence  $f_1 \sqsupset f_0, g$  and  $f_1 \sqsupset \mathbf{b} \sqsupset \mathbf{a}$ . However,  $\mathcal{R}$  is not terminating. Note that  $g_{\mathcal{A}}$  is not monotone. Next consider the algebra  $\mathcal{B}$  over the carrier  $\{0, 1\}$  with  $1 \succ 0$  and operations  $f_{\mathcal{B}}(x) = 0$ ,  $g_{\mathcal{B}}(x) = x$ ,  $\mathbf{a}_{\mathcal{B}} = 0$ , and  $\mathbf{b}_{\mathcal{B}} = 1$ . If  $\ell_f(x) = 1 - x$  then we obtain the same TRS  $\overline{\mathcal{R}}$  as before. Note that now  $\ell_f$  is not monotone.

If the algebra  $\mathcal{A}$  is a model of the ETRS  $\mathcal{R}/\mathcal{E}$  then (similar to ordinary semantic labelling [24]) we can dispense with Dec. Moreover, in this case the converse of Theorem 1 also holds. This is expressed in the next theorem.

**Theorem 2.** *Let  $\mathcal{R}/\mathcal{E}$  be an ETRS over a signature  $\mathcal{F}$ ,  $(\mathcal{A}, \succ)$  a monotone  $\mathcal{F}$ -algebra, and  $\ell$  a monotone labelling for  $\mathcal{A}$ . If  $\mathcal{A}$  is a model of  $\mathcal{R}/\mathcal{E}$  then ter-*

mination of  $\mathcal{R}_{\text{lab}}/\overline{\mathcal{E}}$  is equivalent to termination of  $\mathcal{R}/\mathcal{E}$ .

*Proof.* The following statements are obtained by a straightforward modification of the proof of Theorem 1:

1. if  $s \rightarrow_{\mathcal{R}} t$  then  $\text{lab}_{\alpha}(s) \sim_{\overline{\mathcal{E}}} \cdot \rightarrow_{\mathcal{R}_{\text{lab}}} \text{lab}_{\alpha}(t)$ ,
2. if  $s \vdash_{\mathcal{E}} t$  then  $\text{lab}_{\alpha}(s) \sim_{\overline{\mathcal{E}}} \text{lab}_{\alpha}(t)$ .

Note that since  $\mathcal{A}$  is a model we have  $[\alpha]_{\mathcal{A}}(C'[l\sigma]) \sim [\alpha]_{\mathcal{A}}(C'[r\sigma])$  and hence  $a \sim b$  in the induction step. This explains why there is no need for Dec. So termination of  $\mathcal{R}_{\text{lab}}/\overline{\mathcal{E}}$  implies termination of  $\mathcal{R}/\mathcal{E}$ . The converse also holds; eliminating all labels in an infinite  $\mathcal{R}_{\text{lab}}/\overline{\mathcal{E}}$ -rewrite sequence yields an infinite  $\mathcal{R}/\mathcal{E}$ -rewrite sequence (because there are infinitely many  $\mathcal{R}_{\text{lab}}$ -steps).  $\square$

If the quasi-model  $\mathcal{A}$  in Theorem 1 is equipped with a partial order (i.e., a reflexive, transitive, and anti-symmetric relation)  $\succeq$  instead of a quasi-order  $\succsim$  then we can dispense with Eq.

**Theorem 3.** *Let  $\mathcal{R}/\mathcal{E}$  be an ETRS over a signature  $\mathcal{F}$ ,  $(\mathcal{A}, \succeq)$  a monotone  $\mathcal{F}$ -algebra, and  $\ell$  a monotone labelling for  $\mathcal{A}$ . If  $\mathcal{A}$  is a quasi-model of  $\mathcal{R}/\mathcal{E}$  and  $\overline{\mathcal{R}}/\mathcal{E}_{\text{lab}}$  is terminating then  $\mathcal{R}/\mathcal{E}$  is terminating.*

*Proof.* The proof of Theorem 1 applies; because the equivalence associated with a partial order is the identity relation we have  $\text{Eq} = \emptyset$ .  $\square$

The first example in this section shows that the converse of Theorem 3 does not hold. Combining the preceding two theorems yields the following result.

**Corollary 1.** *Let  $\mathcal{R}/\mathcal{E}$  be an ETRS over a signature  $\mathcal{F}$ ,  $(\mathcal{A}, \succeq)$  a monotone  $\mathcal{F}$ -algebra, and  $\ell$  a monotone labelling for  $\mathcal{A}$ . If  $\mathcal{A}$  is a model of  $\mathcal{R}/\mathcal{E}$  then termination of  $\mathcal{R}_{\text{lab}}/\mathcal{E}_{\text{lab}}$  is equivalent to termination of  $\mathcal{R}/\mathcal{E}$ .*  $\square$

Note that if the pair  $(\mathcal{A}, \succeq)$  is a model of  $\mathcal{R}/\mathcal{E}$  then so is  $(\mathcal{A}, =)$ . Since in this case monotonicity of both the algebra operations and the labelling functions is trivially satisfied, we can rephrase the above corollary as follows.

**Corollary 2.** *Let  $\mathcal{R}/\mathcal{E}$  be an ETRS over a signature  $\mathcal{F}$ ,  $\mathcal{A}$  an  $\mathcal{F}$ -algebra, and  $\ell$  a labelling for  $\mathcal{A}$ . If  $\mathcal{A}$  is a model of  $\mathcal{R}/\mathcal{E}$  then termination of  $\mathcal{R}_{\text{lab}}/\mathcal{E}_{\text{lab}}$  is equivalent to termination of  $\mathcal{R}/\mathcal{E}$ .*  $\square$

Note that the unspecified quasi-order is assumed to be the identity relation, so model here means  $l =_{\mathcal{A}} r$  for all rules  $l \rightarrow r \in \mathcal{R}$  and all equations  $l \approx r \in \mathcal{E}$ .

Let us conclude this section by illustrating the power of equational semantic labelling on a concrete example. Consider the ETRS  $\mathcal{R}/\mathcal{E}$  with  $\mathcal{R} = \{x - 0 \rightarrow x, \mathfrak{s}(x) - \mathfrak{s}(y) \rightarrow x - y, 0 \div \mathfrak{s}(y) \rightarrow 0, \mathfrak{s}(x) \div \mathfrak{s}(y) \rightarrow \mathfrak{s}((x - y) \div \mathfrak{s}(y))\}$  and  $\mathcal{E} = \{(x \div y) \div z \approx (x \div z) \div y\}$ . Let  $\mathcal{A}$  be the algebra with carrier  $\mathbb{N}$ , standard order  $\geq$ , and operations  $0_{\mathcal{A}} = 0$ ,  $\mathfrak{s}_{\mathcal{A}}(x) = x + 1$ , and  $x -_{\mathcal{A}} y = x \div_{\mathcal{A}} y = x$ . This algebra is a quasi-model of  $\mathcal{R}/\mathcal{E}$ . If  $\ell_{\div}(x, y) = x$  then we have  $\mathcal{R}_{\text{lab}} = \{x - 0 \rightarrow x, \mathfrak{s}(x) - \mathfrak{s}(y) \rightarrow x - y, 0 \div_0 \mathfrak{s}(y) \rightarrow 0\} \cup \{\mathfrak{s}(x) \div_{n+1} \mathfrak{s}(y) \rightarrow \mathfrak{s}((x - y) \div_n \mathfrak{s}(y)) \mid n \geq 0\}$ ,  $\text{Dec} = \{x \div_m y \rightarrow x \div_n y \mid m > n\}$ , and  $\mathcal{E}_{\text{lab}} = \{(x \div_n y) \div_n z \approx$

$(x \dot{\div}_n z) \dot{\div}_n y \mid n \geq 0$ . Termination of  $\overline{\mathcal{R}}/\mathcal{E}_{\text{lab}}$  can be shown by the following polynomial interpretation:  $[0] = 0$ ,  $[s](x) = x + 1$ ,  $x[-]y = x + y + 1$ , and  $x[\dot{\div}_n]y = x + ny + n + y$  for all  $n \geq 0$ . According to Theorem 3 the original ETRS  $\mathcal{R}/\mathcal{E}$  is terminating as well. Note that a direct termination proof with standard techniques is impossible since an instance of the last rule of  $\mathcal{R}$  is self-embedding. In order to make this rule non-self-embedding it is essential that we label  $\dot{\div}$ . This explains why Zantema’s version of equational semantic labelling—presented in the next section—will fail here.

## 4 Semantic Labelling Cube

The original version of equational semantic labelling described in Zantema [24] is presented below.

**Theorem 4** ([24]). *Let  $\mathcal{R}/\mathcal{E}$  be an ETRS over a signature  $\mathcal{F}$ ,  $\mathcal{A}$  an  $\mathcal{F}$ -algebra, and  $\ell$  a labelling for  $\mathcal{A}$  such that function symbols occurring in  $\mathcal{E}$  are unlabelled. If  $\mathcal{A}$  is a model of  $\mathcal{R}/\mathcal{E}$  then termination of  $\mathcal{R}_{\text{lab}}/\mathcal{E}$  is equivalent to termination of  $\mathcal{R}/\mathcal{E}$ .  $\square$*

In [24] it is remarked that the restriction that symbols in  $\mathcal{E}$  are unlabelled is essential. Corollary 2, of which Theorem 4 is an immediate consequence, shows that this is not true. Zantema provides the non-terminating ETRS  $\mathcal{R}/\mathcal{E}$  with  $\mathcal{R} = \{(x + y) + z \rightarrow x + (y + z)\}$  and  $\mathcal{E} = \{x + y \approx y + x\}$ , and the model  $\mathcal{A}$  consisting of the positive integers  $\mathbb{N}_+$  with the function symbol  $+$  interpreted as addition. By labelling  $+$  with the value of its first argument, we obtain  $\mathcal{R}_{\text{lab}} = \{(x +_i y) +_{i+j} z \rightarrow x +_i (y +_j z) \mid i, j \in \mathbb{N}_+\}$  and  $\mathcal{E}_{\text{lab}} = \{x +_i y \approx y +_j x \mid i, j \in \mathbb{N}_+\}$ . According to Corollary 2 the labelled ETRS  $\mathcal{R}_{\text{lab}}/\mathcal{E}_{\text{lab}}$  is not terminating and indeed there are infinite rewrite sequences, e.g.

$$(x +_1 x) +_2 x \rightarrow x +_1 (x +_1 x) \sim (x +_1 x) +_2 x \rightarrow \dots$$

In [24] it is remarked that  $\mathcal{R}_{\text{lab}}/\mathcal{E}'$  with  $\mathcal{E}' = \{x +_i y \rightarrow y +_i x \mid i \in \mathbb{N}_+\}$  is terminating, since it is compatible with the polynomial interpretation in which the function symbol  $+_i$  is interpreted as addition plus  $i$ , for every  $i \in \mathbb{N}_+$ . However,  $\mathcal{E}'$  is *not* a labelled version of  $\mathcal{E}$ .

The various versions of equational semantic labelling presented above differ in three choices: (1) the order on the algebra  $\mathcal{A}$  (partial order vs. quasi-order), (2) the relation between the algebra  $\mathcal{A}$  and the ETRS  $\mathcal{R}/\mathcal{E}$  (model vs. quasi-model), and (3) the labelling of the function symbols appearing in  $\mathcal{E}$  (forbidden vs. allowed). This naturally gives rise to the cube of eight versions of equational semantic labelling possibilities shown in Figure 1. Every possibility is given as a string of three choices, each of them indicated by  $-/+$  and ordered as above, so  $-++$  denotes the version of equational semantic labelling with partial order, quasi-model, and (possibly) labelled function symbols in  $\mathcal{E}$ . All eight versions of equational semantic labelling are sound, i.e., termination of the labelled ETRS implies termination of the original ETRS. The versions in which termination

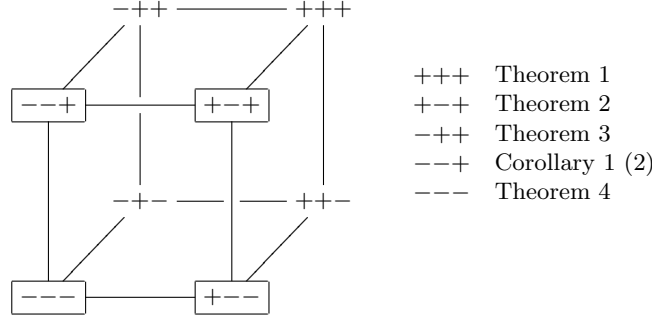

**Fig. 1.** Equational semantic labelling cube.

of the labelled ETRS is equivalent to termination of the original ETRS are indicated by a surrounding box.

We present one more version of equational semantic labelling, stating that the implication of Theorem 1 becomes an equivalence in the special case that  $\mathcal{E}$  is variable preserving (i.e., every equation  $l \approx r \in \mathcal{E}$  has the property that  $l$  and  $r$  have the same number of occurrences of each variable), the (strict part of the) quasi-order  $\succsim$  is well founded, and function symbols occurring in  $\mathcal{E}$  are unlabelled. In other words, if  $\mathcal{E}$  is variable preserving (which in particular is true for AC) and the quasi-order  $\succsim$  is well founded then we can put a box around  $++-$  in Figure 1. Before presenting the proof, we show the necessity of the three conditions. First consider the ETRS  $\mathcal{R}/\mathcal{E}$  with  $\mathcal{R} = \emptyset$  and  $\mathcal{E} = \{f(x, x) \approx x\}$  where the signature contains a unary function symbol  $g$  in addition to the function symbol  $f$ . Let  $\mathcal{A}$  be the algebra over the carrier  $\{0, 1\}$  with  $1 \succ 0$  and operations  $f_{\mathcal{A}}(x, y) = x$  and  $g_{\mathcal{A}}(x) = x$ . Note that  $\mathcal{A}$  is a (quasi-)model of  $\mathcal{R}/\mathcal{E}$ . By labelling  $g$  with the value of its argument, we obtain the ETRS  $\overline{\mathcal{R}}/\overline{\mathcal{E}}$  with  $\overline{\mathcal{R}} = \text{Dec} = \{g_1(x) \rightarrow g_0(x)\}$  and  $\overline{\mathcal{E}} = \mathcal{E}$ . The ETRS  $\mathcal{R}/\mathcal{E}$  is trivially terminating, but  $\overline{\mathcal{R}}/\overline{\mathcal{E}}$  admits the following infinite rewrite sequence:

$$g_1(x) \sim f(g_1(x), g_1(x)) \rightarrow f(g_0(x), g_1(x)) \sim f(g_0(x), f(g_1(x), g_1(x))) \rightarrow \dots$$

Note that  $\mathcal{E}$  is not variable preserving. The necessity of the well-foundedness of the quasi-order  $\succsim$  follows by considering the terminating TRS  $\mathcal{R}/\mathcal{E}$  with  $\mathcal{R} = \{f(x) \rightarrow g(x)\}$  and  $\mathcal{E} = \emptyset$ , the algebra  $\mathcal{A}$  over the carrier  $\mathbb{Z}$  with standard order  $\geq$  and operations  $f_{\mathcal{A}}(x) = g_{\mathcal{A}}(x) = x$ , and the labelling  $l_f(x) = x$ . In this case we have  $\mathcal{R}_{\text{lab}} = \{f_i(x) \rightarrow g(x) \mid i \in \mathbb{Z}\}$  and  $\text{Dec} = \{f_i(x) \rightarrow f_j(x) \mid i > j\}$ , so  $\overline{\mathcal{R}}$  lacks termination. Finally, the requirement that function symbols occurring in  $\mathcal{E}$  must be unlabelled is justified by the counterexample following Theorem 1.

**Theorem 5.** *Let  $\mathcal{R}/\mathcal{E}$  be an ETRS over a signature  $\mathcal{F}$  with  $\mathcal{E}$  variable preserving,  $(\mathcal{A}, \succsim)$  a monotone  $\mathcal{F}$ -algebra with  $\succsim$  well-founded, and  $\ell$  a monotone labelling for  $(\mathcal{A}, \succsim)$  such that function symbols occurring in  $\mathcal{E}$  are unlabelled. If  $\mathcal{A}$  is a quasi-model of  $\mathcal{R}/\mathcal{E}$  then termination of  $\overline{\mathcal{R}}/\overline{\mathcal{E}}$  is equivalent to termination of  $\mathcal{R}/\mathcal{E}$ .*



*Proof.* First note that  $\overline{\mathcal{R}/\mathcal{E}} = (\mathcal{R}_{\text{lab}} \cup \text{Dec})/(\mathcal{E} \cup \text{Eq})$  because function symbols occurring in  $\mathcal{E}$  are unlabelled. The “if” part is a consequence of Theorem 1. For the “only if” part we show that the ETRS  $\text{Dec}/(\mathcal{E} \cup \text{Eq})$  is terminating. For a term  $t \in \mathcal{T}(\mathcal{F}_{\text{lab}}, \mathcal{V})$  let  $\phi(t)$  denote the multiset of all labels occurring in  $t$ . The following facts are not difficult to show:

- if  $s \rightarrow_{\text{Dec}} t$  then  $\phi(s) \succ_{\text{mul}} \phi(t)$ ,
- if  $s \vdash_{\text{Eq}} t$  then  $\phi(s) \sim_{\text{mul}} \phi(t)$ ,
- if  $s \vdash_{\mathcal{E}} t$  then  $\phi(s) = \phi(t)$ .

Here  $\succ_{\text{mul}}$  denotes the multiset extension of  $\succ$  ([5]) and  $\sim_{\text{mul}}$  denotes the multiset extension of the equivalence relation  $\sim$  (which coincides with the equivalence relation associated with the multiset extension  $\succsim_{\text{mul}}$  of  $\succsim$ , see e.g. [17, Definition 5.6]). For the validity of the last observation it is essential that  $\mathcal{E}$  is variable preserving and that function symbols occurring in  $\mathcal{E}$  are unlabelled. From these facts and the well-foundedness of  $\succsim_{\text{mul}}$  we obtain the termination of  $\text{Dec}/(\mathcal{E} \cup \text{Eq})$ . Now, if  $\overline{\mathcal{R}/\mathcal{E}}$  is not terminating then it admits an infinite rewrite sequence which contains infinitely many  $\mathcal{R}_{\text{lab}}$ -steps. Erasing all labels yields an infinite  $\mathcal{R}/\mathcal{E}$ -rewrite sequence, contradicting the assumption that  $\mathcal{R}/\mathcal{E}$  is terminating.  $\square$

## 5 Dummy Elimination for Equational Rewriting

Ferreira, Kesner, and Puel [7] extended dummy elimination [8] to AC-rewriting by completely removing the AC-axioms. We show that their result is easily obtained in our equational semantic labelling framework. Our definition of  $\text{dummy}(\mathcal{R})$  is different from the one in [7, 8], but easily seen to be equivalent.

**Definition 3.** *Let  $\mathcal{R}$  be a TRS over a signature  $\mathcal{F}$ . Let  $e$  be a distinguished function symbol in  $\mathcal{F}$  of arity  $m \geq 1$  and let  $\diamond$  be a fresh constant. We write  $\mathcal{F}_{\diamond}$  for  $(\mathcal{F} \setminus \{e\}) \cup \{\diamond\}$ . The mapping  $\text{cap}: \mathcal{T}(\mathcal{F}, \mathcal{V}) \rightarrow \mathcal{T}(\mathcal{F}_{\diamond}, \mathcal{V})$  is inductively defined as follows:  $\text{cap}(t) = t$  if  $t \in \mathcal{V}$ ,  $\text{cap}(e(t_1, \dots, t_m)) = \diamond$ , and  $\text{cap}(f(t_1, \dots, t_n)) = f(\text{cap}(t_1), \dots, \text{cap}(t_n))$  if  $f \neq e$ . The mapping  $\text{dummy}$  assigns to every term in  $\mathcal{T}(\mathcal{F}, \mathcal{V})$  a subset of  $\mathcal{T}(\mathcal{F}_{\diamond}, \mathcal{V})$ :*

$$\text{dummy}(t) = \{\text{cap}(t)\} \cup \{\text{cap}(s) \mid s \text{ is an argument of an } e \text{ symbol in } t\}.$$

Finally, we define

$$\text{dummy}(\mathcal{R}) = \{\text{cap}(l) \rightarrow r' \mid l \rightarrow r \in \mathcal{R} \text{ and } r' \in \text{dummy}(r)\}.$$

Note that  $\text{dummy}(\mathcal{R})$  may contain invalid rewrite rules because  $\text{cap}(l)$  can have fewer variables than  $l$ . In that case, however,  $\text{dummy}(\mathcal{R})$  is not terminating and the results presented below hold vacuously. Ferreira and Zantema [8] showed that if  $\text{dummy}(\mathcal{R})$  is terminating then  $\mathcal{R}$  is terminating. A simple proof of this fact using *self-labelling*, a special case of semantic labelling, can be found in Middeldorp *et al.* [16]. Two extensions of this result to equational rewriting are known. In [6] Ferreira showed that termination of  $\mathcal{R}/\mathcal{E}$  follows from termination of  $\text{dummy}(\mathcal{R})/\mathcal{E}$  provided that  $\mathcal{E}$  is variable preserving and does not contain the function symbol  $e$ . The extension presented in Ferreira *et al.* [7] is stated below.

**Theorem 6.** *Let  $\mathcal{R}/\mathcal{E}$  be an ETRS with  $\mathcal{E} = \text{AC}(e)$ . If  $\text{dummy}(\mathcal{R})$  is terminating then  $\mathcal{R}/\mathcal{E}$  is terminating.*

In other words, AC-termination of  $\mathcal{R}$  is reduced to termination of  $\text{dummy}(\mathcal{R})$ .

*Proof.* We turn the set of terms  $\mathcal{T}(\mathcal{F}_\diamond, \mathcal{V})$  into an  $\mathcal{F}$ -algebra  $\mathcal{A}$  by defining  $e_{\mathcal{A}}(t_1, \dots, t_n) = \diamond$  and  $f_{\mathcal{A}}(t_1, \dots, t_n) = f(t_1, \dots, t_n)$  for all other function symbols  $f \in \mathcal{F}$  and terms  $t_1, \dots, t_n \in \mathcal{T}(\mathcal{F}_\diamond, \mathcal{V})$ . We equip  $\mathcal{A}$  with the (well-founded) partial order  $\succeq = \rightarrow_{\text{dummy}(\mathcal{R})}^*$ . One can verify that  $\mathcal{A}$  is monotone with respect to  $\succeq$ . An easy induction proof shows that  $[\alpha](t) = \text{cap}(t)\alpha$  for all terms  $t \in \mathcal{T}(\mathcal{F}, \mathcal{V})$ . We show that  $\mathcal{A}$  is a quasi-model of  $\mathcal{R}/\mathcal{E}$ . Let  $\alpha: \mathcal{V} \rightarrow \mathcal{T}(\mathcal{F}_\diamond, \mathcal{V})$  be an arbitrary assignment and let  $l \rightarrow r \in \mathcal{R}$ . We have  $[\alpha](l) = \text{cap}(l)\alpha$  and  $[\alpha](r) = \text{cap}(r)\alpha$  by the above property. The rewrite rule  $\text{cap}(l) \rightarrow \text{cap}(r)$  belongs to  $\text{dummy}(\mathcal{R})$  by definition and hence  $[\alpha](l) \succeq [\alpha](r)$ . For the two equations  $l \approx r \in \mathcal{E}$  we clearly have  $[\alpha](l) = \diamond = [\alpha](r)$ . Hence  $\mathcal{A}$  is a quasi-model of  $\mathcal{R}/\mathcal{E}$ .

Define the (monotone) labelling  $\ell$  as follows:  $\ell_f = f_{\mathcal{A}}$  for all function symbols  $f \in \mathcal{F}$ . According to Theorem 3 it is sufficient to show that  $\overline{\mathcal{R}}/\mathcal{E}_{\text{lab}}$  is terminating. Define a precedence  $\sqsupset$  on  $\mathcal{F}_{\text{lab}}$  as follows:  $f_s \sqsupset g_t$  if and only if  $s (\succ \cup \triangleright)^+ t$ , where  $\triangleright$  is the proper superterm relation. Note that  $\sqsupset$  inherits well-foundedness from  $\succ$ . We claim that  $\overline{\mathcal{R}}$  is precedence terminating with respect to  $\sqsupset$ . Rewrite rules in Dec are of the form  $f_s(x_1, \dots, x_n) \rightarrow f_t(x_1, \dots, x_n)$  with  $s \succ t$  and thus  $f_s \sqsupset f_t$ . For rules in  $\mathcal{R}_{\text{lab}}$  we make use of the following property:

$$\text{if } t \trianglelefteq r \text{ then } \text{cap}(t) \trianglelefteq r' \text{ for some term } r' \in \text{dummy}(r). \quad (*)$$

Now let  $l \rightarrow r \in \mathcal{R}_{\text{lab}}$ . By definition there exist an assignment  $\alpha: \mathcal{V} \rightarrow \mathcal{T}(\mathcal{F}_\diamond, \mathcal{V})$  and a rewrite rule  $l' \rightarrow r' \in \mathcal{R}$  such that  $l = \text{lab}_\alpha(l')$  and  $r = \text{lab}_\alpha(r')$ . The label of the root symbol of  $l$  is  $[\alpha](l') = \text{cap}(l')\alpha$ . Let  $s$  be the label of a function symbol in  $r$ . By construction  $s = [\alpha](t) = \text{cap}(t)\alpha$  for some subterm  $t$  of  $r'$ . According to (1) we have  $\text{cap}(t) \trianglelefteq r''$  for some  $r'' \in \text{dummy}(r')$ . By definition  $\text{cap}(l') \rightarrow r'' \in \text{dummy}(\mathcal{R})$  and hence  $\text{cap}(l')\alpha \succ r''\alpha \triangleright \text{cap}(t)\alpha = s$ . Consequently,  $\text{root}(l) \sqsupset f$  for every function symbol  $f$  in  $r$ . This completes the proof of precedence termination of  $\overline{\mathcal{R}}$ . Since  $\mathcal{E}_{\text{lab}} = \text{AC}(e_\diamond)$ , termination of  $\overline{\mathcal{R}}/\mathcal{E}_{\text{lab}}$  follows from Lemma 1.  $\square$

The reader is invited to compare our proof with the one in [7]. For the above simple proof we indeed needed our new powerful version of equational semantic labelling, i.e., Zantema's restricted version (Theorem 4) would not have worked.

One may wonder whether the soundness proof of the version of equational dummy elimination presented in [6] can also be simplified by equational semantic labelling. This turns out not to be the case. One reason is that function symbols of  $\mathcal{E}$  that also appear in  $\mathcal{R}$  will be labelled, causing  $\mathcal{E}_{\text{lab}}$  (and  $\overline{\mathcal{E}}$ ) to be essentially different from  $\mathcal{E}$ . In particular, if  $\mathcal{E}$  consists of AC-axioms then  $\mathcal{E}_{\text{lab}}$  contains non-AC axioms and hence AC-compatible orders are not applicable to  $\overline{\mathcal{R}}/\overline{\mathcal{E}}$ . Moreover, Lemma 1 does not extend to arbitrary ESs  $\mathcal{E}$  and it is unclear how to change the definition of precedence termination such that it does.

Recently, Nakamura and Toyama [18] improved dummy elimination by restricting  $r'$  in the definition of  $\text{dummy}(\mathcal{R})$  to terms in  $(\text{dummy}(r) \setminus \mathcal{T}(\mathcal{F}_{\mathcal{C}}, \mathcal{V})) \cup$

$\{\text{cap}(r)\}$  with  $\mathcal{F}_C$  denoting the constructors of  $\mathcal{R}$ . In other words, elements of  $\text{dummy}(r) \setminus \{\text{cap}(r)\}$  that do not contain a defined function symbol need not be considered when forming the right-hand sides of the rewrite rules in  $\text{dummy}(\mathcal{R})$ . For example, the TRS  $\mathcal{R} = \{\mathbf{f}(\mathbf{a}) \rightarrow \mathbf{f}(\mathbf{b}), \mathbf{b} \rightarrow \mathbf{e}(\mathbf{a})\}$  is transformed into the non-terminating TRS  $\text{dummy}(\mathcal{R}) = \{\mathbf{f}(\mathbf{a}) \rightarrow \mathbf{f}(\mathbf{b}), \mathbf{b} \rightarrow \diamond, \mathbf{b} \rightarrow \mathbf{a}\}$  by dummy elimination whereas the above improvement yields the terminating TRS  $\{\mathbf{f}(\mathbf{a}) \rightarrow \mathbf{f}(\mathbf{b}), \mathbf{b} \rightarrow \diamond\}$ . Aoto<sup>1</sup> suggested that a further improvement is possible by stripping off the outermost constructor context of every element in  $\text{dummy}(r) \setminus \{\text{cap}(r)\}$ . For  $\mathcal{R} = \{\mathbf{f}(\mathbf{a}(x)) \rightarrow \mathbf{f}(\mathbf{b}), \mathbf{b} \rightarrow \mathbf{e}(\mathbf{a}(\mathbf{f}(\mathbf{c})))\}$  this would yield the terminating TRS  $\{\mathbf{f}(\mathbf{a}(x)) \rightarrow \mathbf{f}(\mathbf{b}), \mathbf{b} \rightarrow \diamond, \mathbf{b} \rightarrow \mathbf{f}(\mathbf{c})\}$  whereas the transformation of [18] produces  $\text{dummy}(\mathcal{R}) = \{\mathbf{f}(\mathbf{a}(x)) \rightarrow \mathbf{f}(\mathbf{b}), \mathbf{b} \rightarrow \diamond, \mathbf{b} \rightarrow \mathbf{a}(\mathbf{f}(\mathbf{c}))\}$ , which is clearly not terminating.

These ideas are easily incorporated in our definition of dummy elimination. Here  $\mathcal{F}_D = \mathcal{F} \setminus \mathcal{F}_C$  denotes the defined symbols of  $\mathcal{R}$ .

**Definition 4.** *Let  $\mathcal{R}$  be a TRS over a signature  $\mathcal{F}$ . The mapping  $\text{dummy}'$  assigns to every term in  $\mathcal{T}(\mathcal{F}, \mathcal{V})$  a subset of  $\mathcal{T}(\mathcal{F}_\diamond, \mathcal{V})$ , as follows:*

$$\text{dummy}'(t) = \text{cap}(t) \cup \left\{ \text{cap}(s) \mid \begin{array}{l} s \text{ is a maximal subterm of an argument} \\ \text{of } e \text{ in } t \text{ such that } \text{root}(s) \in \mathcal{F}_D \setminus \{e\} \end{array} \right\}.$$

We define

$$\text{dummy}'(\mathcal{R}) = \{\text{cap}(l) \rightarrow r' \mid l \rightarrow r \in \mathcal{R} \text{ and } r' \in \text{dummy}'(r)\}.$$

**Theorem 7.** *Let  $\mathcal{R}/\mathcal{E}$  be an ETRS with  $\mathcal{E} = \text{AC}(e)$ . If  $\text{dummy}'(\mathcal{R})$  is terminating then  $\mathcal{R}/\mathcal{E}$  is terminating.*

*Proof.* Very similar to the proof of Theorem 6. The difference is that we do not label the function symbols in  $\mathcal{F}_C$ . In order to obtain precedence termination of  $\overline{\mathcal{R}}$  we extend the precedence  $\sqsupset$  on  $\mathcal{F}_{\text{lab}}$  by  $f_t \sqsupset g$  for every  $f \in \mathcal{F}_D$ ,  $t \in \mathcal{T}(\mathcal{F}_\diamond, \mathcal{V})$ , and  $g \in \mathcal{F}_C$ . In addition, (\*) is replaced by the following property:

$$\text{if } t \leq r \text{ and } \text{root}(t) \in \mathcal{F}_D \text{ then } \text{cap}(t) \leq r' \text{ for some term } r' \in \text{dummy}'(r).$$

Taking these changes into consideration, termination of  $\mathcal{R}/\mathcal{E}$  is obtained as in the proof of Theorem 6.  $\square$

## 6 Distribution Elimination for Equational Rewriting

Next we show that our results on equational semantic labelling can also be used to extend the distribution elimination transformation of [23] to the AC case. Again, for that purpose we need our powerful version of equational semantic labelling, i.e., Theorem 4 does not suffice. Let  $\mathcal{R}$  be a TRS over a signature  $\mathcal{F}$  and let  $e \in \mathcal{F}$  be a designated function symbol whose arity is at least one. A

<sup>1</sup> Remark made at the 14th Japanese Term Rewriting Meeting, Nara Institute of Science and Technology, March 15–16, 1999.

rewrite rule  $l \rightarrow r \in \mathcal{R}$  is called a *distribution rule* for  $e$  if  $l = C[e(x_1, \dots, x_m)]$  and  $r = e(C[x_1], \dots, C[x_m])$  for some non-empty context  $C$  in which  $e$  does not occur and pairwise different variables  $x_1, \dots, x_m$ . Distribution elimination is a technique that transforms  $\mathcal{R}$  by eliminating all distribution rules for  $e$  and removing the symbol  $e$  from the right-hand sides of the other rules. Let  $\mathcal{F}_{\text{distr}} = \mathcal{F} \setminus \{e\}$ . We inductively define a mapping  $\text{distr}$  that assigns to every term in  $\mathcal{T}(\mathcal{F}, \mathcal{V})$  a non-empty subset of  $\mathcal{T}(\mathcal{F}_{\text{distr}}, \mathcal{V})$ , as follows:

$$\text{distr}(t) = \begin{cases} \{t\} & \text{if } t \in \mathcal{V}, \\ \bigcup_{i=1}^m \text{distr}(t_i) & \text{if } t = e(t_1, \dots, t_m), \\ \{f(s_1, \dots, s_n) \mid s_i \in \text{distr}(t_i)\} & \text{if } t = f(t_1, \dots, t_n) \text{ with } f \neq e. \end{cases}$$

It is extended to rewrite systems as follows:

$$\text{distr}(\mathcal{R}) = \{l \rightarrow r' \mid l \rightarrow r \in \mathcal{R} \text{ is no distribution rule for } e \text{ and } r' \in \text{distr}(r)\}.$$

A rewrite system is called *right-linear* if no right-hand side of a rule contains multiple occurrences of the same variable. The following theorem extends Zanema's soundness result for distribution elimination to the AC case.

**Theorem 8.** *Let  $\mathcal{R}/\mathcal{E}$  be an ETRS with  $\mathcal{E} = \text{AC}(e)$  such that  $e$  does not occur in the left-hand sides of rewrite rules of  $\mathcal{R}$  that are not distribution rules for  $e$ . If  $\text{distr}(\mathcal{R})$  is terminating and right-linear then  $\mathcal{R}/\mathcal{E}$  is terminating.*

*Proof.* We turn the set of finite non-empty multisets over  $\mathcal{T}(\mathcal{F}_{\text{distr}}, \mathcal{V})$  into an  $\mathcal{F}$ -algebra  $\mathcal{A}$  by defining

$$f_{\mathcal{A}}(M_1, \dots, M_n) = \begin{cases} \{f(t_1, \dots, t_n) \mid t_i \in M_i \text{ for all } 1 \leq i \leq n\} & \text{if } f \neq e, \\ M_1 \cup M_2 & \text{if } f = e \end{cases}$$

for all function symbols  $f \in \mathcal{F}$  and finite non-empty multisets  $M_1, \dots, M_n$  of terms in  $\mathcal{T}(\mathcal{F}_{\text{distr}}, \mathcal{V})$ . (Note that  $n = 2$  if  $f = e$ .) We equip  $\mathcal{A}$  with the (well-founded) partial order  $\succeq = \succ_{\text{mul}}^-$  where  $\succ = \rightarrow_{\text{distr}(\mathcal{R})}^+$ . One easily shows that  $(\mathcal{A}, \succeq)$  is a monotone  $\mathcal{F}$ -algebra. It can be shown (cf. the nontrivial proof of Theorem 12 in [23]) that

1.  $l =_{\mathcal{A}} r$  for every distribution rule  $l \rightarrow r \in \mathcal{R}$ ,
2.  $l \succ_{\mathcal{A}} r$  for every other rule  $l \rightarrow r \in \mathcal{R}$ .

For (2) we need the right-linearity assumption of  $\text{distr}(\mathcal{R})$ . From the definition of  $e_{\mathcal{A}}$  we obtain  $e(x, y) =_{\mathcal{A}} e(y, x)$  and  $e(e(x, y), z) =_{\mathcal{A}} e(x, e(y, z))$ . Hence  $(\mathcal{A}, \succeq)$  is a quasi-model of  $\mathcal{R}/\mathcal{E}$ .

Define the (monotone) labelling  $\ell$  as follows:  $\ell_f = f_{\mathcal{A}}$  for all function symbols  $f \neq e$ . According to Theorem 3 it is sufficient to show that  $\overline{\mathcal{R}}/\mathcal{E}_{\text{lab}}$  is terminating. Define the precedence  $\sqsupset$  on  $\mathcal{F}_{\text{lab}}$  as follows:  $f \sqsupset g$  if and only if either  $f \neq e$  and  $g = e$  or  $f = f'_M$  and  $g = g'_N$  with  $M ((\succ \cup \triangleright)^+)_{\text{mul}} N$ . Note that  $\sqsupset$  is well founded. We claim that  $\overline{\mathcal{R}}$  is precedence terminating with respect to  $\sqsupset$ . Rewrite

rules in  $\text{Dec}$  are of the form  $f_M(x_1, \dots, x_n) \rightarrow f_N(x_1, \dots, x_n)$  with  $M \succ_{\text{mul}} N$  and thus  $f_M \sqsupset f_N$ . For rules in  $\mathcal{R}_{\text{lab}}$  we make use of the following property, which is not difficult to prove:

3. if  $t \triangleleft r$  then  $[\alpha](r) \triangleright_{\text{mul}} [\alpha](t)$  for every assignment  $\alpha$ .

Now let  $l \rightarrow r \in \mathcal{R}_{\text{lab}}$ . By definition there is an assignment  $\alpha: \mathcal{V} \rightarrow \mathcal{T}(\mathcal{F}_{\text{distr}}, \mathcal{V})$  and a rewrite rule  $l' \rightarrow r' \in \mathcal{R}$  such that  $l = \text{lab}_\alpha(l')$  and  $r = \text{lab}_\alpha(r')$ . Since  $\text{root}(l') \neq e$ , the label of the root symbol of  $l$  is  $[\alpha](l')$ . If  $e$  occurs in  $r'$  then  $\text{root}(l) \sqsupset e$  by definition. Let  $M$  be the label of a function symbol in  $r$ . By construction  $M = [\alpha](t)$  for some subterm  $t$  of  $r'$ . We distinguish two cases. First consider the case that  $l' \rightarrow r' \in \mathcal{R}$  is a distribution rule. Because  $\text{root}(r') = e$ ,  $t$  is a proper subterm of  $r'$ . Property (3) yields  $[\alpha](r') \triangleright_{\text{mul}} [\alpha](t)$ . We have  $[\alpha](l') = [\alpha](r')$  by (1). Hence  $[\alpha](l') ((\succ \cup \triangleright)^+)_{\text{mul}} M$  as required. Next let  $l' \rightarrow r' \in \mathcal{R}$  be a non-distribution rule. From (3) we infer that  $[\alpha](r') \succeq_{\text{mul}} [\alpha](t)$  (if  $t = r'$  then  $[\alpha](r') = [\alpha](t)$  holds). According to (2) we have  $[\alpha](l') \succ_{\text{mul}} [\alpha](r')$ . Hence also in this case we obtain  $[\alpha](l') ((\succ \cup \triangleright)^+)_{\text{mul}} M$ . This completes the proof of precedence termination of  $\overline{\mathcal{R}}/\mathcal{E}_{\text{lab}}$ . Since  $\mathcal{E}_{\text{lab}} = \mathcal{E} = \text{AC}(e)$ , termination of  $\overline{\mathcal{R}}/\mathcal{E}_{\text{lab}}$  follows from Lemma 1.  $\square$

Next we show that the right-linearity requirement in the preceding theorem can be dropped if termination is strengthened to *total termination*. A TRS is called totally terminating if it is compatible with a well-founded monotone algebra in which the underlying order is total. Since adding a constant to the signature does not affect total termination, from now on we assume that the set of ground terms is non-empty. Total termination is equivalent (see [9, Theorem 13]) to compatibility with a well-founded monotone total order on ground terms. Here, “compatibility” means that  $l\sigma \succ r\sigma$  holds for all rules  $l \rightarrow r \in \mathcal{R}$  and all substitutions such that  $l\sigma$  is a ground term. It should be noted that standard termination techniques like polynomial interpretations, recursive path order, and Knuth-Bendix order all yield total termination.

**Theorem 9.** *Let  $\mathcal{R}/\mathcal{E}$  be an ETRS with  $\mathcal{E} = \text{AC}(e)$  such that  $e$  does not occur in the left-hand sides of rewrite rules of  $\mathcal{R}$  that are not distribution rules for  $e$ . If  $\text{distr}(\mathcal{R})$  is totally terminating then  $\mathcal{R}/\mathcal{E}$  is terminating.*

*Proof.* There is a well-founded monotone total order  $\succ$  on  $\mathcal{T}(\mathcal{F}_{\text{distr}})$  which is compatible with  $\text{distr}(\mathcal{R})$ . We turn  $\mathcal{T}(\mathcal{F}_{\text{distr}})$  into an  $\mathcal{F}$ -algebra  $\mathcal{A}$  by defining  $f_{\mathcal{A}}(t_1, \dots, t_n) = f(t_1, \dots, t_n)$  if  $f \neq e$  and  $f_{\mathcal{A}}(t_1, \dots, t_n) = \max\{t_1, t_2\}$  if  $f = e$  for all symbols  $f \in \mathcal{F}$  and terms  $t_1, \dots, t_n$  in  $\mathcal{T}(\mathcal{F}_{\text{distr}})$ . We equip  $\mathcal{A}$  with the (well-founded) partial order  $\succeq$ . One can show that  $(\mathcal{A}, \succeq)$  is a monotone  $\mathcal{F}$ -algebra. It is not difficult to verify that  $l =_{\mathcal{A}} r$  for every distribution rule  $l \rightarrow r \in \mathcal{R}$  and the two equations  $l \approx r \in \mathcal{E}$ . An easy induction proof shows that

1. for all terms  $r \in \mathcal{T}(\mathcal{F}, \mathcal{V})$  and assignments  $\alpha$  there exists a term  $s \in \text{distr}(r)$  such that  $[\alpha](r) = [\alpha](s)$ .

Using this property, we obtain (by induction on  $r$ ) that  $l \succ_{\mathcal{A}} r$  for every non-distribution rule  $l \rightarrow r \in \mathcal{R}$ . Hence  $(\mathcal{A}, \succeq)$  is a quasi-model of  $\mathcal{R}/\mathcal{E}$ .

Define the (monotone) labelling  $\ell$  as follows:  $\ell_f = f_{\mathcal{A}}$  for all function symbols  $f \neq e$ . According to Theorem 3 it is sufficient to show that  $\overline{\mathcal{R}}/\mathcal{E}_{\text{lab}}$  is terminating. Define the precedence  $\sqsupset$  on  $\mathcal{F}_{\text{lab}}$  as follows:  $f \sqsupset g$  if and only if either  $f \neq e$  and  $g = e$  or  $f = f'_s$  and  $g = g'_t$  with  $s (\succ \cup \triangleright)^+ t$ . Note that  $\sqsupset$  is well founded. The following property is not difficult to prove:

2. if  $t \triangleleft r$  then  $[\alpha](r) \triangleright [\alpha](t)$  for every assignment  $\alpha$ .

However,  $[\alpha](r) \triangleright [\alpha](t)$  need not hold (consider e.g.  $t \triangleleft e(t, t)$ ) and as a consequence the labelled distribution rules in  $\overline{\mathcal{R}}$  are not precedence terminating with respect to  $\sqsupset$ . Nevertheless, the precedence termination of the labelled non-distribution rules in  $\mathcal{R}_{\text{lab}}$  as well as the rules in Dec is obtained as in the proof of Theorem 8. Hence any AC-compatible recursive path order  $\sqsupset_{\text{rpo}}^{\text{AC}}$  induced by the precedence  $\sqsupset$  that is defined on terms with variables (cf. the proof of Lemma 1) will orient these rules from left to right. Let  $l = C[e(x, y)] \rightarrow e(C[x], C[y]) = r$  be a distribution rule in  $\mathcal{R}$  and let  $\alpha$  be an arbitrary assignment. We claim that  $\text{lab}_{\alpha}(l) \sqsupset_{\text{rpo}}^{\text{AC}} \text{lab}_{\alpha}(r)$ . Since  $C \neq \square$ ,  $\text{root}(\text{lab}_{\alpha}(l)) \sqsupset e = \text{root}(\text{lab}_{\alpha}(r))$  by definition. It suffices to show that  $\text{lab}_{\alpha}(l) \sqsupset_{\text{rpo}}^{\text{AC}} \text{lab}_{\alpha}(C[x])$  and  $\text{lab}_{\alpha}(l) \sqsupset_{\text{rpo}}^{\text{AC}} \text{lab}_{\alpha}(C[y])$ . We have  $\text{lab}_{\alpha}(C[x]) = C_1[x]$ ,  $\text{lab}_{\alpha}(C[y]) = C_2[y]$  for some labelled contexts  $C_1$  and  $C_2$ , and  $\text{lab}_{\alpha}(l) = C_1[e(x, y)]$  if  $\alpha(x) \succeq \alpha(y)$  and  $\text{lab}_{\alpha}(l) = C_2[e(x, y)]$  otherwise. We consider only the case  $\alpha(x) \succeq \alpha(y)$  here. We have  $C_1[e(x, y)] \sqsupset_{\text{rpo}}^{\text{AC}} C_1[x]$  by the subterm property of  $\sqsupset_{\text{rpo}}^{\text{AC}}$ . If  $\alpha(x) = \alpha(y)$  then  $C_2[y] = C_1[y]$  and thus also  $C_1[e(x, y)] \sqsupset_{\text{rpo}}^{\text{AC}} C_2[y]$  by the subterm property. If  $\alpha(x) \succ \alpha(y)$  then  $C_1[e(x, y)] \sqsupset_{\text{rpo}}^{\text{AC}} C_2[y]$  because the rewrite rule  $C_1[e(x, y)] \rightarrow C_2[y]$  is precedence terminating. This can be seen as follows. The label of the root symbol of  $C_1[e(x, y)]$  is  $[\alpha](C[x])$ . Let  $q$  be the label of a function symbol in  $C_2[y]$ . By construction  $q = [\alpha](t)$  for some subterm  $t$  of  $C[y]$ . We obtain  $[\alpha](C[y]) \triangleright [\alpha](t) = q$  from (2). The monotonicity of  $\mathcal{A}$  yields  $[\alpha](C[x]) \succ [\alpha](C[y])$ . Hence  $[\alpha](C[x]) (\succ \cup \triangleright)^+ q$  as desired. We conclude that  $\overline{\mathcal{R}}/\mathcal{E}_{\text{lab}}$  is terminating. Theorem 3 yields the termination of  $\mathcal{R}/\mathcal{E}$ .  $\square$

The above theorem extends a similar result for TRSs in Zantema [23]. Actually, in [23] it is shown that  $\mathcal{R}$  is *totally* terminating if  $\text{distr}(\mathcal{R})$  is totally terminating. Our semantic labelling proof does not give total termination of  $\mathcal{R}/\mathcal{E}$ . Nevertheless, the more complicated proof in [23] can be extended to deal with  $\text{AC}(e)$ , so  $\mathcal{R}/\mathcal{E}$  is in fact totally terminating.

In Middeldorp *et al.* [16] it is shown that for  $\mathcal{E} = \emptyset$  the right-linearity requirement in Theorem 8 can be dropped if there are no distribution rules in  $\mathcal{R}$ . It remains to be seen whether this result is also true if  $\mathcal{E} = \text{AC}(e)$ . We note that the semantic labelling proof in [16] does not extend to  $\mathcal{R}/\mathcal{E}$  because the interpretation of  $e$  defined there, an arbitrary projection function, is inconsistent with the commutativity of  $e$ .

**Acknowledgements.** We are grateful to the anonymous referees for their careful reading. Aart Middeldorp is partially supported by the Grant-in-Aid for Scientific Research C(2) 11680338 of the Ministry of Education, Science, Sports and Culture of Japan. Jürgen Giesl is supported by the DFG under grant GI 274/4-1.

## References

1. T. Arts and J. Giesl, *Termination of Term Rewriting Using Dependency Pairs*, Theoretical Computer Science 236, pp. 133–178, 2000.
2. A. Ben Cherifa and P. Lescanne, *Termination of Rewriting Systems by Polynomial Interpretations and its Implementation*, Science of Computer Programming 9(2), pp. 137–159, 1987.
3. F. Baader and T. Nipkow, *Term Rewriting and All That*, Cambridge University Press, 1998.
4. N. Dershowitz, *Termination of Rewriting*, Journal of Symbolic Computation 3, pp. 69–116, 1987.
5. N. Dershowitz and Z. Manna, *Proving Termination with Multiset Orderings*, Communications of the ACM 22(8), pp. 465–476, 1979.
6. M.C.F. Ferreira, *Dummy Elimination in Equational Rewriting*, Proc. 7th RTA, LNCS 1103, pp. 78–92, 1996.
7. M.C.F. Ferreira, D. Kesner, and L. Puel, *Reducing AC-Termination to Termination*, Proc. 23rd MFCS, LNCS 1450, pp. 239–247, 1998.
8. M.C.F. Ferreira and H. Zantema, *Dummy Elimination: Making Termination Easier*, Proc. 10th FCT, LNCS 965, pp. 243–252, 1995.
9. M.C.F. Ferreira and H. Zantema, *Total Termination of Term Rewriting*, Applicable Algebra in Engineering, Communication and Computing 7, pp. 133–162, 1996.
10. A. Geser, *Relative Termination*, Ph.D. thesis, Universität Passau, 1990.
11. J.-P. Jouannaud and M. Muñoz, *Termination of a Set of Rules Modulo a Set of Equations*, Proc. 7th CADE, LNCS 170, pp. 175–193, 1984.
12. D. Kapur and G. Sivakumar, *A Total, Ground Path Ordering for Proving Termination of AC-Rewrite Systems*, Proc. 8th RTA, LNCS 1232, pp. 142–155, 1997.
13. D. Kapur, G. Sivakumar, and H. Zhang, *A New Method for Proving Termination of AC-Rewrite Systems*, Proc. 10th FSTTCS, LNCS 472, pp. 133–148, 1990.
14. C. Marché and X. Urbain, *Termination of Associative-Commutative Rewriting by Dependency Pairs*, Proc. 9th RTA, LNCS 1379, pp. 241–255, 1998.
15. A. Middeldorp and H. Ohsaki, *Type Introduction for Equational Rewriting*, Acta Informatica, 2000. To appear.
16. A. Middeldorp, H. Ohsaki, and H. Zantema, *Transforming Termination by Self-Labeling*, Proc. 13th CADE, LNAI 1104, pp. 373–387, 1996.
17. A. Middeldorp, H. Zantema, *Simple Termination of Rewrite Systems*, Theoretical Computer Science 175, pp. 127–158, 1997.
18. M. Nakamura and Y. Toyama, *On Proving Termination by General Dummy Elimination*, Technical report of IEICE, COMP 98-58 (1998-11), pp. 57–64, 1998. In Japanese.
19. A. Rubio, *A Fully Syntactic AC-RPO*, Proc. 10th RTA, LNCS 1631, pp. 133–147, 1999.
20. A. Rubio and R. Nieuwenhuis, *A Total AC-Compatible Ordering Based on RPO*, Theoretical Computer Science 142, pp. 209–227, 1995.
21. J. Steinbach, *Termination of Rewriting: Extensions, Comparison and Automatic Generation of Simplification Orderings*, Ph.D. thesis, Univ. Kaiserslautern, 1994.
22. Y. Toyama, *Counterexamples to Termination for the Direct Sum of Term Rewriting Systems*, Information Processing Letters 25, pp. 141–143, 1987.
23. H. Zantema, *Termination of Term Rewriting: Interpretation and Type Elimination*, Journal of Symbolic Computation 17, pp. 23–50, 1994.
24. H. Zantema, *Termination of Term Rewriting by Semantic Labelling*, Fundamenta Informaticae 24, pp. 89–105, 1995.